

180AP Quick Setup Guide

Please read and understand Section 1 safety, Section 3 Installation & Adjustment and Section 4 Operation in the owner's manual that came with your 180AP.

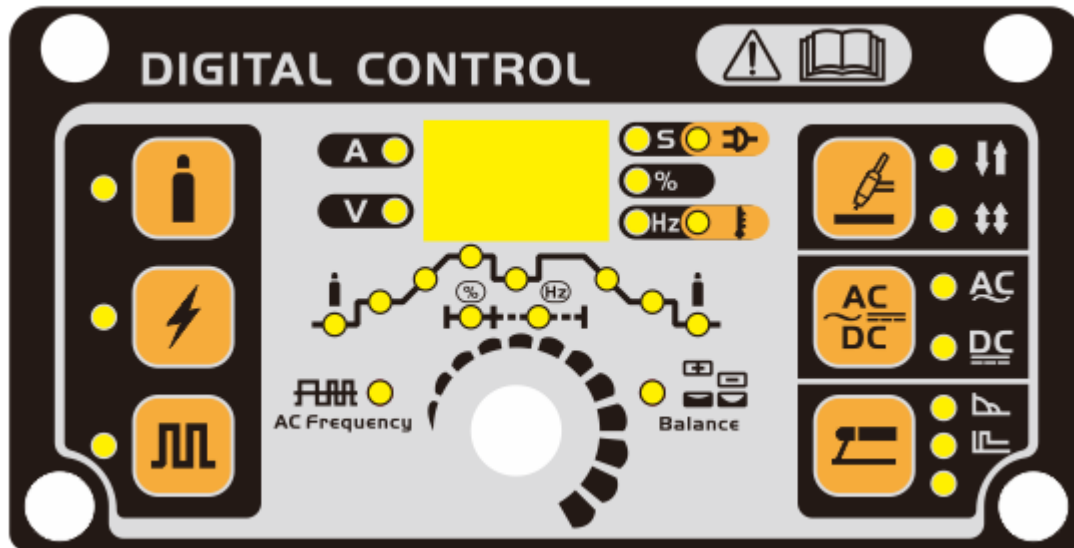

180AP TIG Setup

- Gas Purge – Pressing this button turns on the gas solenoid. Pressing the Gas Purge button again shuts off the gas solenoid.



- HF Start - For HF non-contact arc starting Press the HF Start button. The yellow light illuminates.
 - For Lift TIG contact arc starting HF light is OFF.



- Pulse – To select Pulse TIG mode Press the Pulse button. Yellow light will illuminate.
 - Pulse parameters are Iw, Ib, Dcy, Fp.
 - Iw – Peak current
 - Ib – Background Current
 - Dcy – Ratio of time spent at peak pulse. If set at 50%, then 50% of each cycle will be at peak current.
 - Fp – Pulse Frequency in Cycles Per Second.



- 2T/4T Remote Control – Select 2T (2 arrows one up one down) when using a foot control. Select 4T (2 Double arrows) when using the controls on the supplied TIG torch.



- AC/DC Selection – Selects AC or DC output.



- STICK Functions -  Arc Force,  Hot Start. Select by pushing the STICK button.



- Parameter select & Set – Used to select Parameter and set value. Rotate knob to select parameter. Push knob and then rotate to set parameter value.



Parameter setup

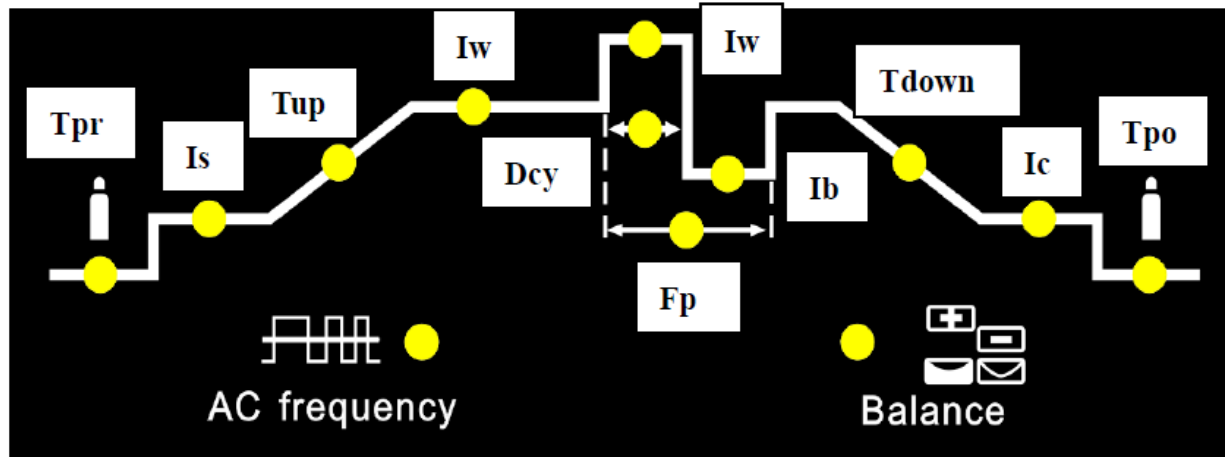

Start left to right. Rotate the red knob to highlight the Parameter to adjust. The yellow light will illuminate to show selection. Push red knob to set parameter value.

1. Tpr - Gas Pre-Flow. Value in seconds.
2. Is – Starting Current. Value in Amperage. Used in 4T mode.
3. Tup – Up Slope Time. Value in seconds. Set to zero when using a foot control.
4. Iw – Welding amperage. Value in Amps.
 - a. Also Peak Pulse when in Pulse Mode.
5. Dcy – Pulse Width. Only available when in Pulse Mode.
6. Fp – Pulse Frequency. Only available when in Pulse Mode.
7. Ib – Background amperage. Only available when in Pulse Mode.
8. Tdown – Down Slope Time. Value in seconds. Set to zero when using a foot control.
9. Ic – Crater current – Value in Amperage. Used in 4T mode.
10. Tpo – Pulse flow – Value in seconds.
11. AC frequency – AC welding frequency. Value in Hertz.
12. Balance – AC welding. Cleaning control. Increasing the percent increases cleaning.

Using supplied TIG Torch

- Supplied TIG Torch has three buttons on the handle.
 - Bigger Button at the top is ON/OFF.
 - The two smaller are amperage control UP and Down.
 - Set the 2T/4T Remote Control Button on the front panel for 4T operation.
 -  4T setting.
 - 4T operation in HF Start mode.
 - Press and hold close the ON/OFF button. Pre flow starts, then HF starts to transfer arc at Starting Current amperage setting.



- Release ON/OFF button. Amperage increases at set up slope time to weld current. Now use the two smaller buttons to increase or decrease amperage while welding.
 - Press and hold close the ON/OFF button again. Amperage decreases at set Down Slope time to crater amperage.
 - Release ON/OFF button. Arc stops then post flow.
-
- TIG operation with Foot Control
 - Set the 2T/4T Remote Control Button on the Front Panel for 2T operation.
 -  2T Setting.
 - Set up slope and Down Slope settings to zero.