

# SanRex

150PW & 300PW Plasma Welding Systems

Replacement of Thermal Arc Ultima 150 or  
WC100B Modular system.

## Sanrex Plasma Welding Systems.

The Sanrex 300PW and 150PW are Plug-n-Play to the Thermal Arc Plasma Welding WC100B Modular system and Ultima 150 system.

### **Thermal Arc WC100B Modular System**

Consist of a DC/CC Power Supply, WC100B Weld Console, HE100A or HE200A Coolant Recirculator and a 2A, 3A, 4A or PWM300 Torch. The Weld Sequencer and remote pendent are options for pulse and slope functions. See figure 1-A.

The 300PW replaces the DC/CC Power Supply the WC100B and the Weld Sequencer.

Thermal Arc Torch connections are standard Oxygen Right Hand B nut female (9/16"-18 Thread). Same as the 300PW. Match each Hose color with color marked on Torch terminal connection board.

Connect the Cooler recirculator coolant hoses to the coolant recirculator fittings on the back panel of the 300PW.

Connect Plasma Gas and Shield gas supplies to gas fittings on the back of the 300PW. Two Gas hoses required. Part number MS1000.

If using the 14 Pin Black Amp receptacle on the WC100B to interface to your fixture you will need a ADC001 adaptor. If connecting to the WC100B terminal strip inside connect matching signals to the terminal strip located on the back of the 300PW. See 300PW Owners manual for I/O signals.

Work lead is not supplied with the 300PW. Work lead connection is a 50mm Dinse receptacle.

# WC100B Modular Plasma Welding System.

The 300PW replaces the WC100B and DC Power Supply.

**X** Items replaced with 300PW.

The Optional Thermal Arc Weld Sequencer includes a Current Pulser, Current Sloper, Weld Timer and Plasma Mass-Flow control if required.

The 300PW includes a Current Pulser and Current Sloper. Optional Plasma Gas Mass-Flow Kit is available. Does not include a Weld Timer.

Optional Remote Pendant or Foot Control available for the 300PW.

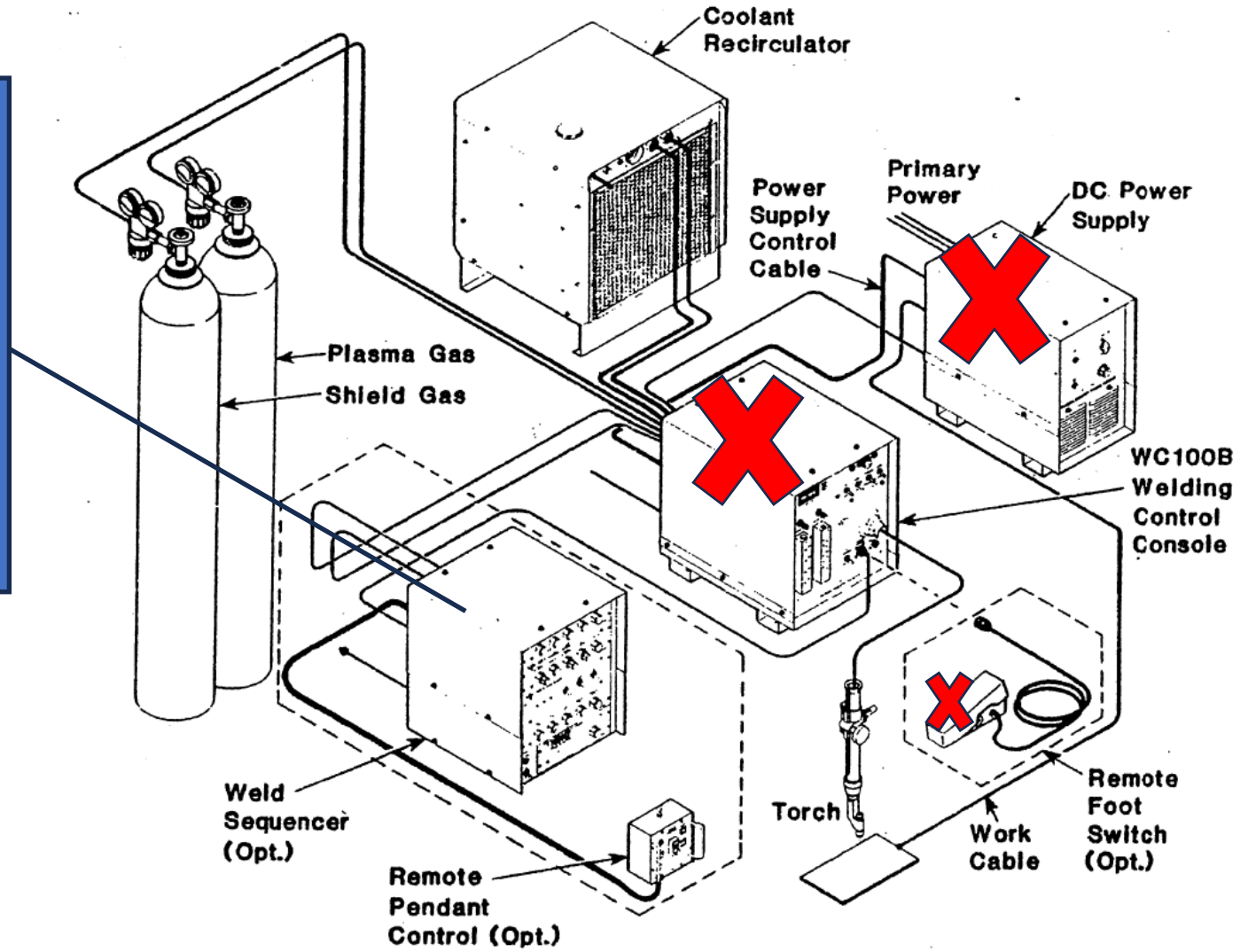

Figure 1-B Plasma Welding System

## Sanrex Plasma Welding Systems.

The Sanrex 300PW and 150PW are Plug-n-Play to the Thermal Arc Plasma Welding WC100B Modular system and Ultima 150 system.

### **Thermal Arc Ultima 150**

The 150PW replaces the complete Ultima 150.

Connect Plasma Gas and Shield gas supplies to gas fittings on the back of the 150PW. Two Gas hoses required. Part number MS1000.

Work lead is not supplied with the 150PW. Work lead connection is a 50mm Dinse receptacle.

If using the 14 Pin Black Amp receptacle on the Ultima 150 to interface to your fixture you will need a ADC001 adaptor. If connecting to the Ultima 150 terminal strip inside connect matching signals to the terminal strip located on the back of the 150PW. See 150PW Owners Manual for I/O signals.

The 150PW includes a simple sequencer with Weld Timer, Current Sloper and Current Pulser.



Optional Remote Pendant or Foot Control available for the 150PW.



# Sanrex Plasma Welding Systems.

The Sanrex 300PW and 150PW are Plug-n-Play to the Thermal Arc Plasma Welding WC100B Modular system and Ultima 150 system.

## Thermal Arc Ultima 150

Ultima 150 Torch includes a quick disconnect. To connect same torch to 150PW you must remove the quick disconnect assy. Remove items 1 through 9 from item 10 torch leads. The torch leads will then connect direct to the 150PW male torch connections. The connections are standard Oxygen "B" RH (9/16"-18 Thread).

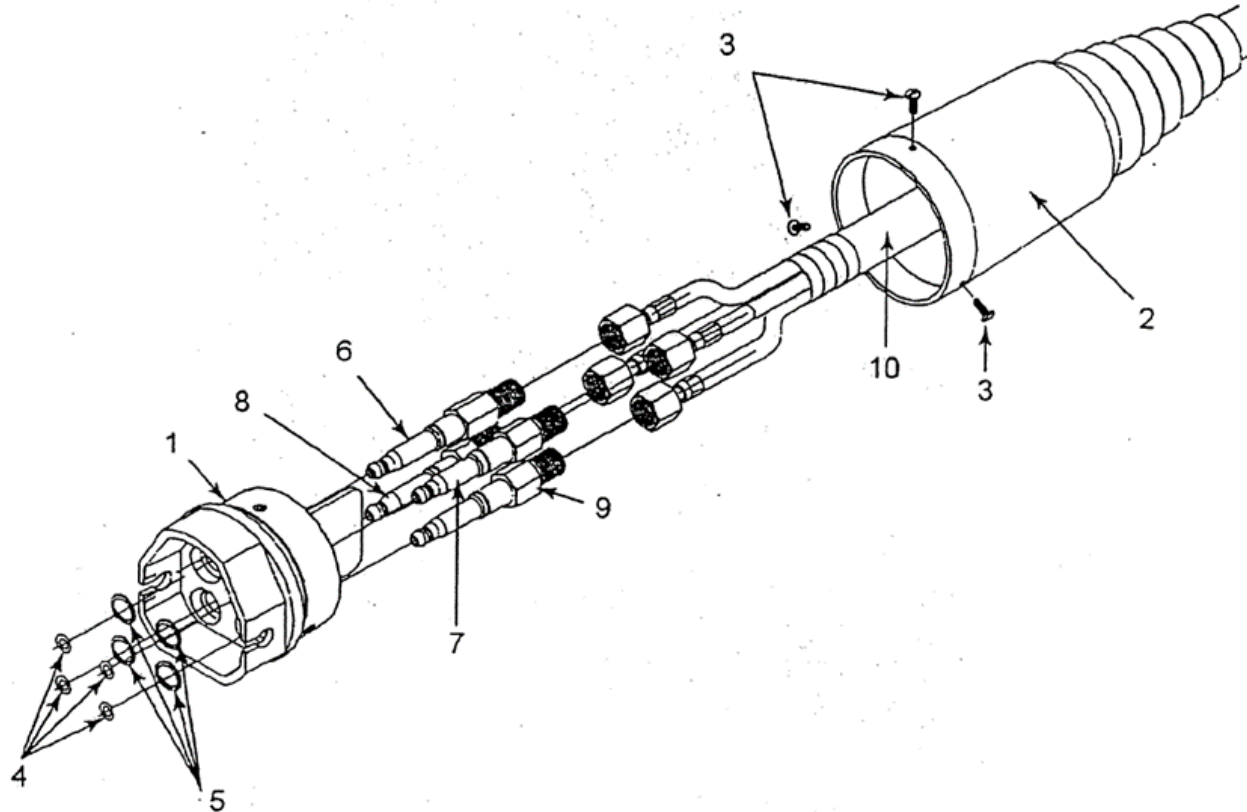

# Sanrex Plasma Welding Systems.

## 300PW and 150PW Torch connections.

Thermal Arc Torch connections are standard Oxygen Right Hand B nut female (9/16"-18 Thread). Match each Hose color with color marked on Torch terminal connection board.



Optional Remote Pendant or Foot Control available for the 150PW.

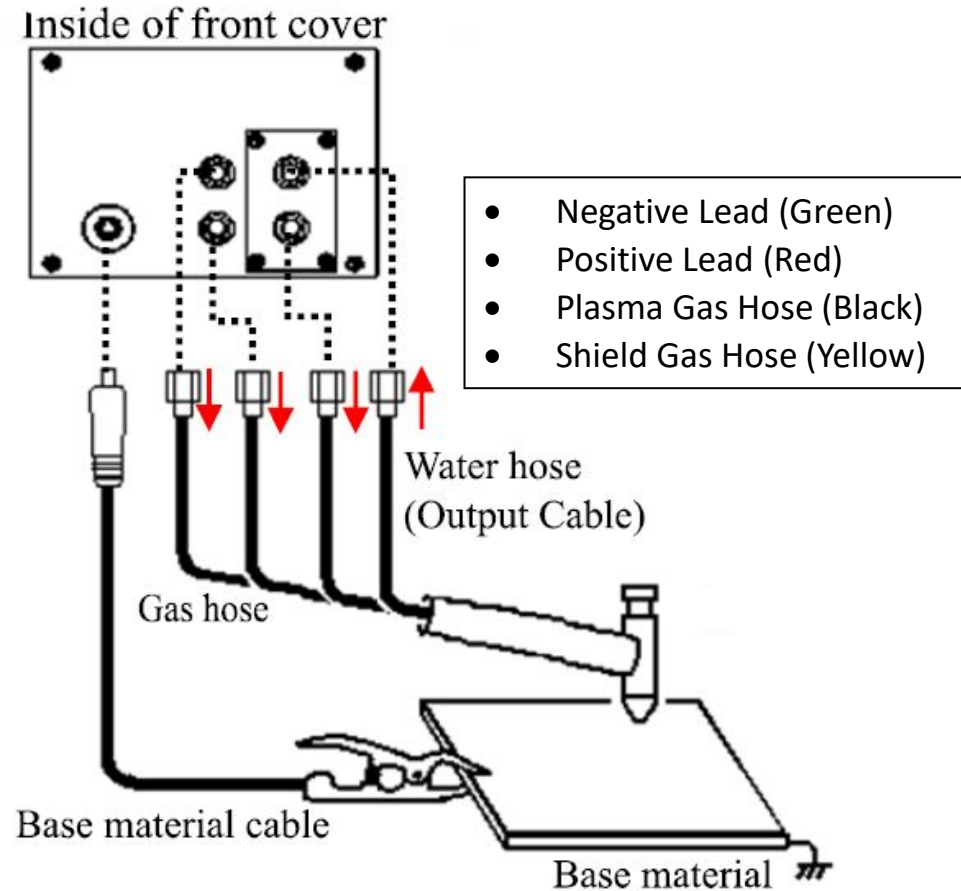

# WC100B Schematic.

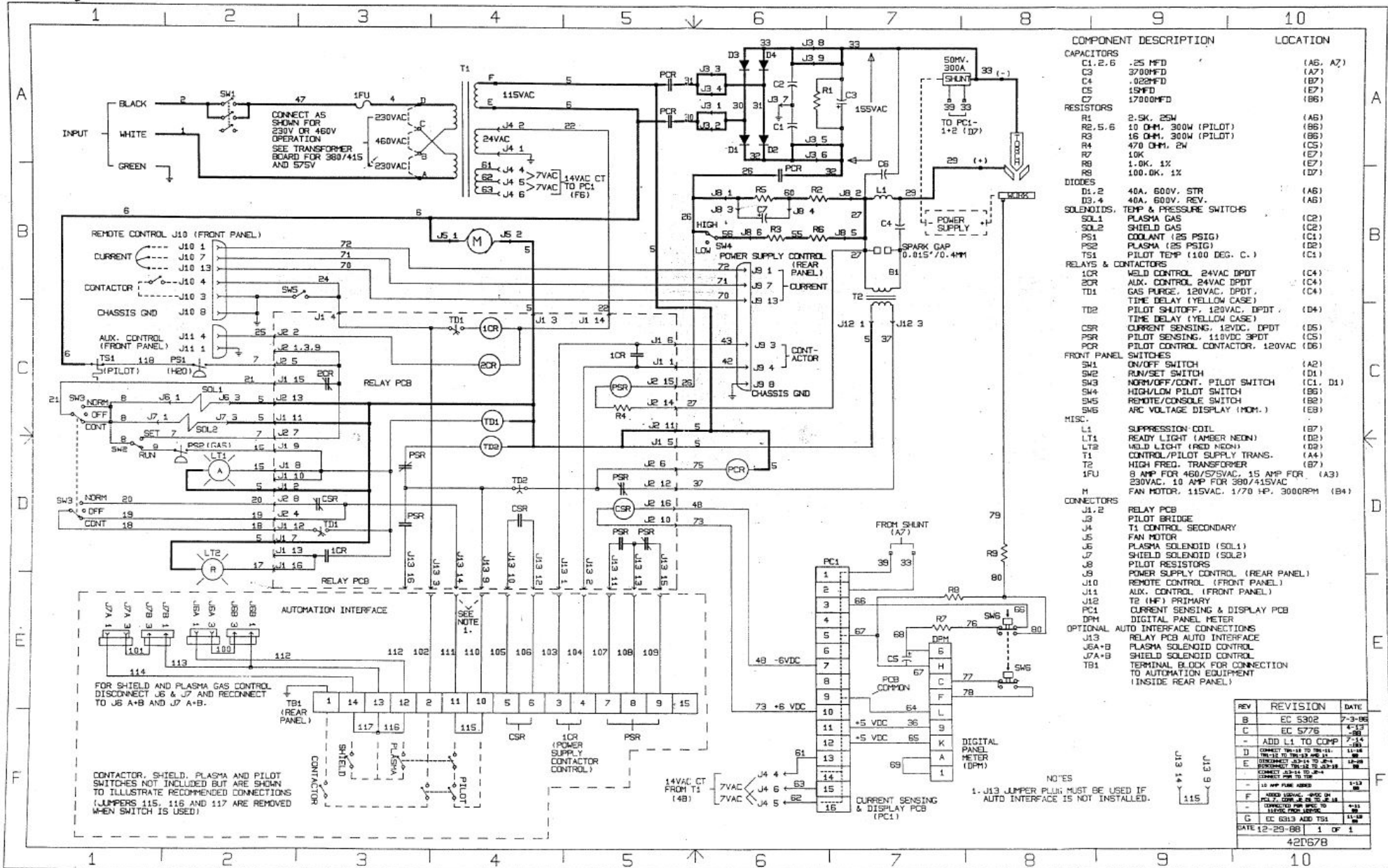

WC100B 14 Pin Amp interface receptacle.

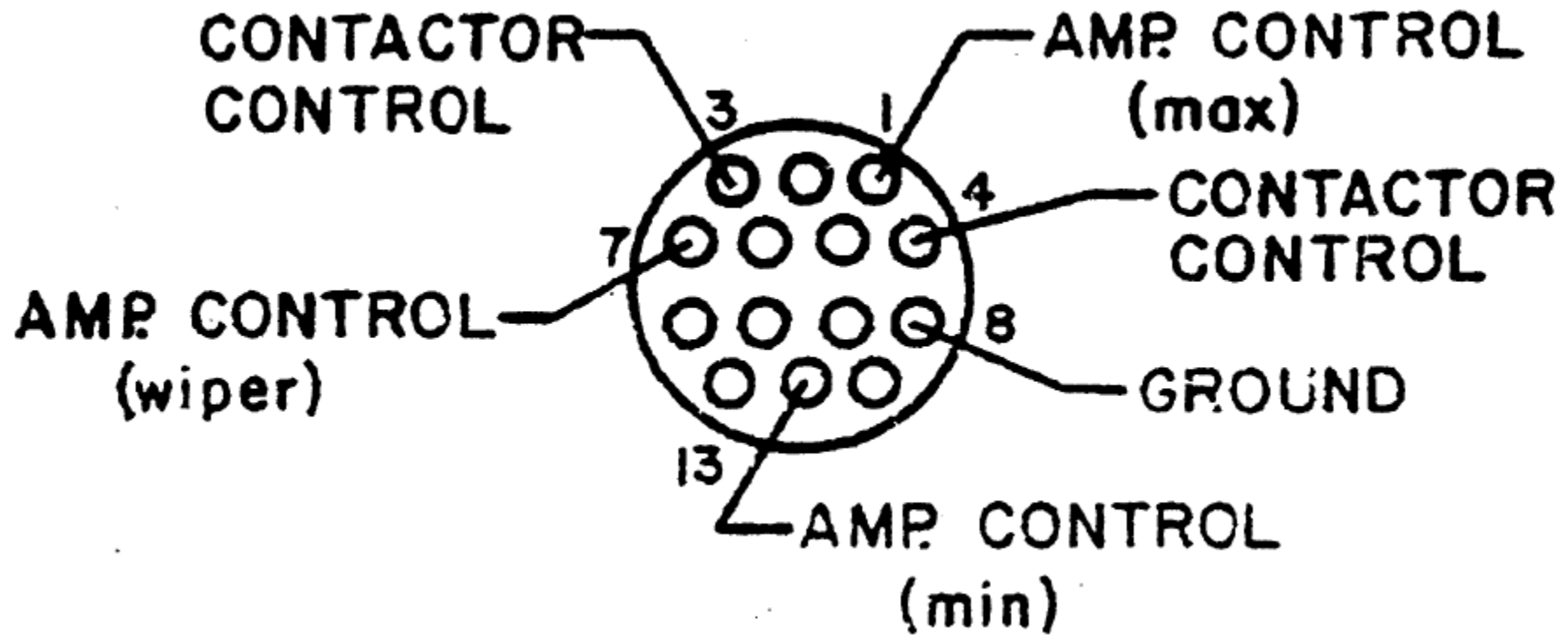



# WC100B I/O Interface Terminal Strip.

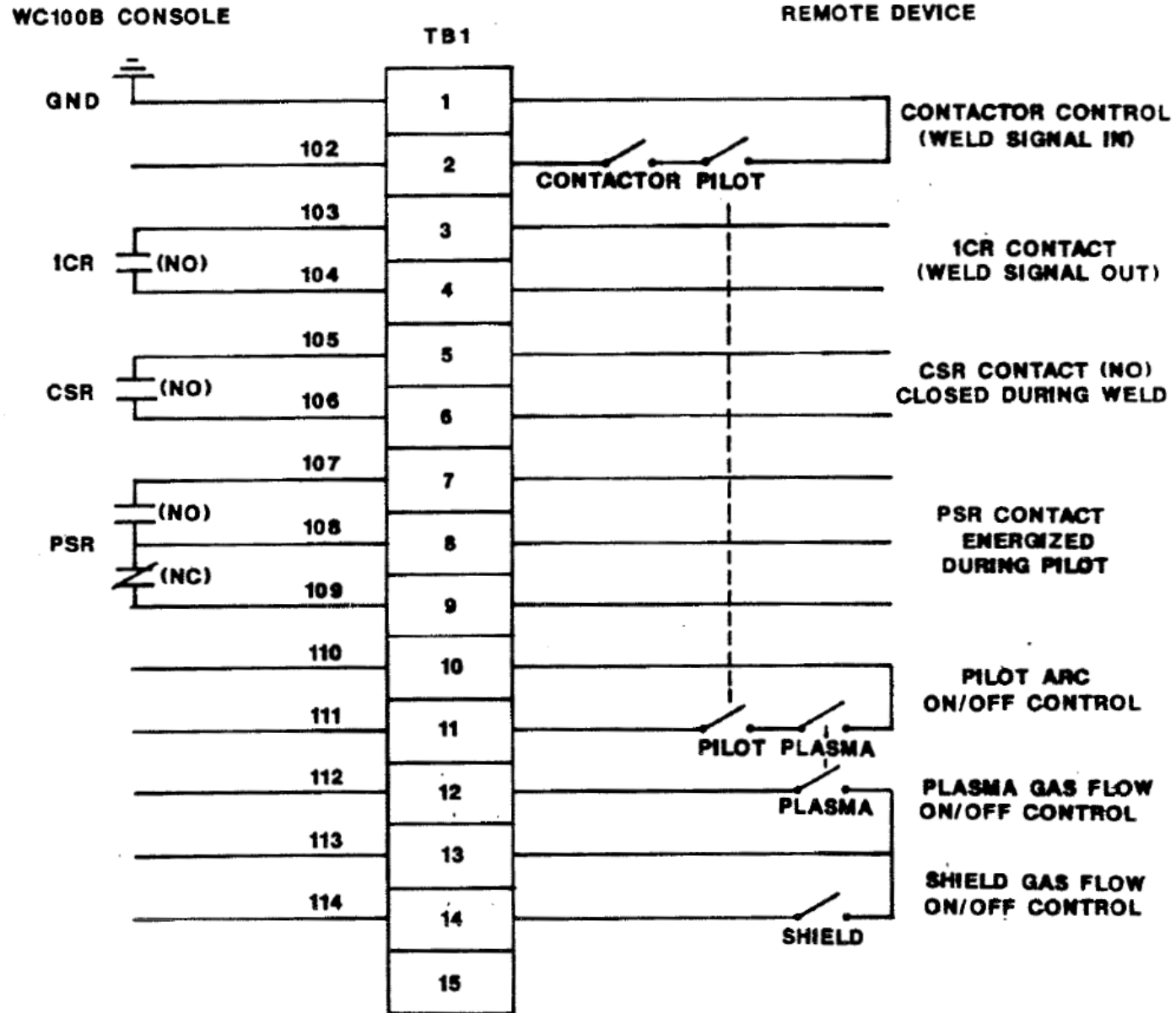

# Ultima 150 I/O Interface.

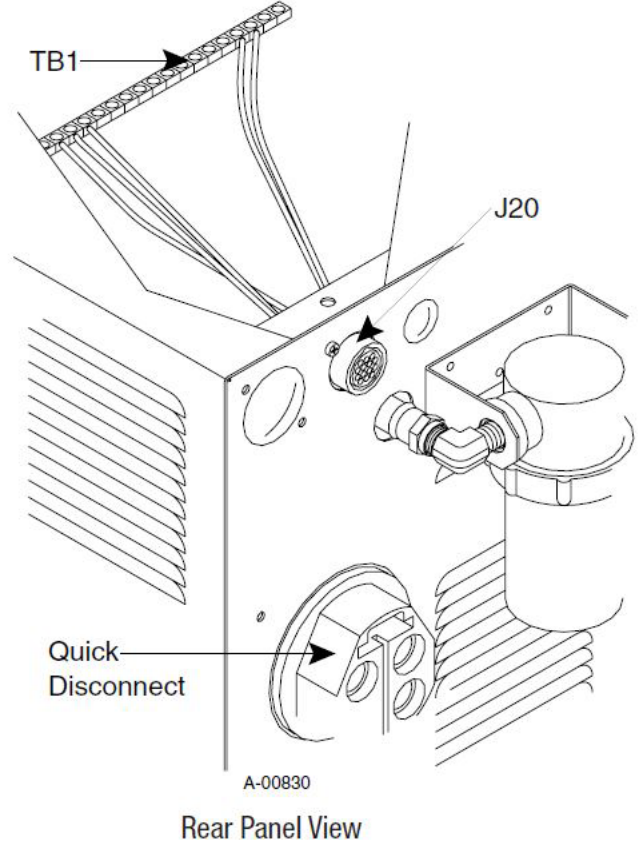
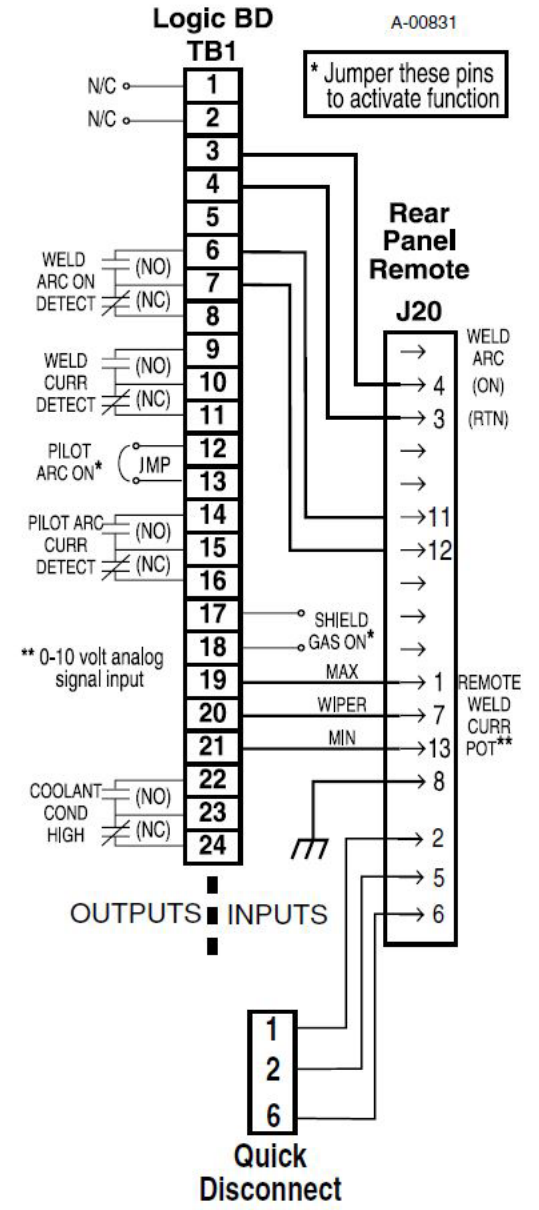

# 150PW 14 Pin Amphenol I/O Interface.

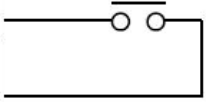
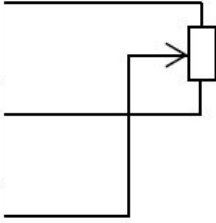
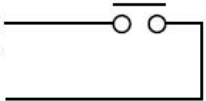
TERMINAL	FUNCTION		DIRECTION	REMARKS
A	Main Start Signal		Input	
B	Main Start Signal (closure between pin A and pin B will energize output)		Input	
C	External Peak	5k ohm (maximum) connection to 5kΩ remote control potentiometer. (+10V, 2mA max)	Output	
D	(welding) Current	Zero-ohm (minimum) connection to 5kΩ remote control potentiometer. (GND)	—	
E	Setting Signal	Wiper arm connection to 5kΩ remote control potentiometer. (0~10V) (*1) (*2)	Input	
F	Scaled Output Main Current Signal: $I_{fb} = 100A/1V$		Output	Max 5mA
G	Chassis Ground		—	
H	Scaled Output Main Voltage Signal: $V_{fb} = 10V/1V$		Output	Max 5mA
I	Control Circuit Common (F & H)		Output	
J	NC		—	
K	Pilot Start Signal		Input	
L	Pilot Start Signal (closure between pin K and pin L will energize output)		Input	
M	OK to Move Current Detect Signal		Output	DC 0.1A / 30V or less
N	OK to Move Current Detect Signal		Output	

(\*1) Enabling the output current setting in Setup to ON when utilizing a Hand Pendant, Foot control or an external current command.

# 150PW Common Terminal Strip I/O Signals.

See manual for additional I/O signals.

Common signals of the External Input / Output Signal Terminal Block and the Remote Controller Outlet are connected to each other inside the welding power supply. (As shown below)

SIGNAL NAME		EXTERNAL INPUT/OUTPUT TERMINAL BLOCK		REMOTE 14 Pin RECEPTACLE
Main Start Signal		1	↔	A
Main Start Signal (common)		2	↔	B
Pilot Start Signal		3	↔	K
Pilot Start Signal(common)		4	↔	L
OK to Move Current Detect Signal		15	↔	M
OK to Move Current Detect Signal		16	↔	N
External Peak (welding) Current Setting Signal	+10V Output	23	↔	C
	0-10V Input	24	↔	E
	GND	25	↔	D
Scaled Output Main Voltage Signal		26	↔	H
Scaled Output Main Current Signal		27	↔	F
Control Circuit Common (for pins 26&27, H & F)		28	↔	I

## 300PW 14 Pin Amphenol I/O Interface.

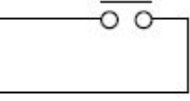
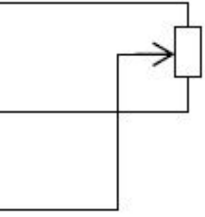
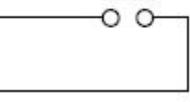
Terminal	Function	Direction	
A	Main Contactor circuit	Input	
B	Main Contactor circuit in (closure between pin A and pin B will energize output)	Input	
C	5k ohm (maximum) connection to 5k ohm remote control potentiometer.(+10V)	Output	
D	Zero ohm (minimum) connection to 5k ohm remote control potentiometer.	—	
E	Wiper arm connection to 5k ohm remote control potentiometer.(0-10V) (*1) (*2)	Input	
F	Scaled output main current signal $I_{fb} = 100A/1V$	Output	Max 5mA
G	Chassis ground	—	
H	Scaled output voltage signal: $V_{fb} = 10V/1V$	Output	Max 5mA
I	Control circuit common (F & H)	Output	
J	NC	—	
K	Pilot Contactor circuit	Input	
L	Pilot Contactor circuit in(closure between pin K and pin L will energize output)	Input	
M	OK to move current detect signal	Output	Max 1A
N	OK to move current detect signal	Output	

(\*1) enable current setting by external current command value when panel on operation panel/ remote switch set as REMOTE.

(\*2) when you use foot remote, set the panel on operation panel/ remote selectin button to REMOTE.

## 300PW Common Terminal Strip I/O Signals.

See manual for additional I/O signals.

Signal Name	External input/output Terminal block		Remote controller outlet
Main Arc on	1	↔	A
Main Arc on (common)	2	↔	B
Pilot Arc on	3	↔	K
Pilot Arc on (common)	4	↔	L
Main current detection output	15	↔	M
Main current detection output	16	↔	N
DC10V output	23	↔	C
Peak (Welding) Current Command Input	24	↔	E
Peak (Welding) Current Command Input (common)	25	↔	D
Main current monitoring output	27	↔	F
Main voltage monitoring output	26	↔	H
Monitoring output (common)	28	↔	I

# I/O Cross Reference.

Most common Signals.

See manual for additional I/O signals.

**Note: Assumes internal wiring has not been Modified from Factory specification.**

150PW	150PW	Ultima 150	Ultima 150	Signal Description
Term. Strip	14 Pin Amphenol	14 Pin Amp	Term. Strip	
TB3		J20	TB1	
1	A	4	3	Weld Arc ON signal from PLC. Dry contact closure between Pin 4.
2	B	3	4	Weld Arc ON Signal from PLC. Dry contact closure between Pin 3.
15	M	12	7	Weld Arc On Detect
16	N	11	6	Weld Arc On Detect
23	C	1	19	Max Remote Weld Current Potentiometer
24	E	7	20	Wiper Remote Weld Current Potentiometer
25	D	13	21	Minimum Remote Weld Current Potentiometer
		8		Earth Ground

300PW	300PW	WC100B	WC100B	Signal Description
Term. Strip	14 Pin Amphenol	14 Pin Amp	Term. Strip	
TB3		J20	TB1	
1	A	4	1	Weld Arc ON signal from PLC. Dry contact closure between Pin 4.
2	B	3	2	Weld Arc ON Signal from PLC. Dry contact closure between Pin 3.
15	M	N/A	3 or 5	Weld Arc On Detect
16	N	N/A	4 or 6	Weld Arc On Detect
23	C	1	19	Max Remote Weld Current Potentiometer
24	E	7	20	Wiper Remote Weld Current Potentiometer
25	D	13	21	Minimum Remote Weld Current Potentiometer
		8		Earth Ground

## 300PW to WC100B I/O Cross Reference.

See manual for additional I/O signals.

***Note: Assumes WC100B internal wiring has not been Modified from Factory specification.***

300PW	300PW	WC100B	WC100B	Signal Description
Term. Strip	14 Pin Amphenol	14 Pin Amp	Term. Strip	
TB3	CON1	J20	TB1	
1	A	4	1	Weld Arc ON signal from PLC. Dry contact closure between Pin 4.
2	B	3	2	Weld Arc ON Signal from PLC. Dry contact closure between Pin 3.
3	K		10	Pilot Start Signal
4	L		11	Pilot Start Signal
5				Gas Check Signal
6				Gas Check Signal
7				E-Stop
8				E-Stop
9				User Saved File selection signal
10				User Saved File selection signal
11				User Saved File selection signal
12				User Saved File selection signal
13				User Saved File selection signal
14				
15	M	N/A	3 or 5	Ok-to-Move Signal
16	N	N/A	4 or 6	Ok-to-Move Signal
17			7	Pilot Current detect signal
18			8	Pilot Current detect signal
19				error detect signal
20				error detect signal
21				Pulse Sync Signal (Open Collector)
22				Pulse Sync Signal (Open Collector)
23	C	1	19	Max Remote Weld Current Potentiometer
24	E	7	20	Wiper Remote Weld Current Potentiometer
25	D	13	21	Minimum Remote Weld Current Potentiometer
26	H			V out Signal
27	F			A out signal
28	I			V/A Out common
	G	8		Earth Ground
			12	Plasma Gas Flow On/OFF Control
			13	12/13 Common
			14	Shield Gas Flow On/Off Control