

Talk about versatility, adjust the SANPAW 150PW Plasma Welding Arc from a soft TIG like Arc to a stable columnar laser like Arc. Can use multiple welding gas combinations to weld any ferrous metals such as Titanium, galvanized, Copper, Stainless Steel, mild steel, etc.

This unique plasma welding system is self-contained in a small package with a 200 amp power supply, coolant recirculator and control console. Our design reduces floor space and simplifies installation, making the initial price competitive with TIG and Laser systems while its increased productivity and repeatable performance allow it to pay for itself in a shorter period of time.

### **Features and Benefits of the SANPAW 150PW**

- 0.5-200 Amp current range - providing quality performance on a wide variety of applications.
- Smooth DC arc - repetitive, high quality welds.
- Pilot Arc - repeatable arc starting reducing defects and rework.
- Multiple Voltage Input - 200-240/480VAC, 1/3 phase, 50 or 60 hz.
- Preview Set Current - eliminates costly test set-ups/displays actual current/voltage.
- Included Weld Sequencer (Current Sloper/Pulser).
- Internal Torch Coolant Recirculator.
- Save 9 Programs.
- Simple interface - automated or manual control.
- Can utilize a number of competitive torches.
- Approvals — CSA (pending); IP23S; IEC 60974-1 (CE)
- 3 Year Warranty

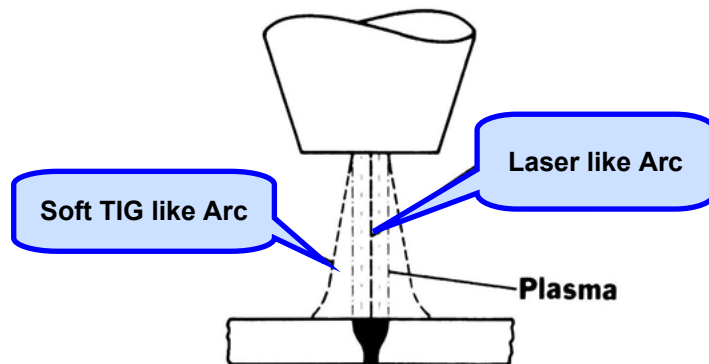

Plasma Welding Arc Modes.



# SANPAW 150PW

## DC Plasma Welding

The SANPAW 150PW Automation system is shipped with a SANPAW 150PW unit, Gas Hoses, Dinse Plug, Coolant and the appropriate torch with a torch spare parts kit. Systems do not include Work Lead, Regulators or remotes. Select system and accessories below. For a Hand Held system see 150PW Easy Find Guide.

Torch (Rating)	System Description	w/12.5 ft. Torch and Leads	w/25 ft. Torch and Leads
P-75 (75 amps)	PWH-75, 70 degree	PAW150P7570H125	PAW150P7570H25
	PWH-75, 90 degree	PAW150P7590H125	PAW150P7590H25
	PWH-75, 180 degree	PAW150P75180H125	PAW150P75180H25
	PWM-75, 180 degree	PAW150P75180M125	PAW150P75180M25
P-15 (150 amps)	PWH-15, 70 degree	PAW150P1570H125	PAW150P1570H25
	PWH-15, 90 degree	PAW150P1590H125	PAW150P1590H25
	PWH-15, 180 degree	PAW150P15180H125	PAW150P15180H25
	PWM-15, 180 degree	PAW150P15180M125	PAW150P15180M25
P-22 (200 amps)	PWH-22, 70 degree	PAW150P2270H125	PAW150P2270H25
	PWH-22, 90 degree	PAW150P2290H125	PAW150P2290H25
	PWH-22, 180 degree	PAW150P22180H125	PAW150P22180H25
	PWH-22A, 180 degree	PAW150P22180H125	PAW150P22180H25
	PWM-22, 180 degree	PAW150P22180M125	PAW150P22180M25
	PWM-22A, 180 degree	PAW150P22180MA125	PAW150P22180MA25

- PWH designates a torch with a molded handle. **(Good for Hand Held.)**
- PWM designates a torch with rack and pinion.
- Torch amperage rating based on minimum electrode set back.

SANPAW 150PW (Unit Only)	IDU-W150PW-U1DVP
12.5 ft. Gas Hose (2 Required)	MS1000
Argon Regulator	MS1005
Hydrogen Regulator	MS1006
Note: 2 regulators required , one for Plasma Gas and one for Shield Gas.	
25ft. Foot Control	FC1001
25ft. Hand Pendant	HP1425
1ft. Adaptor, 14-Pin Amp to 14-Pin Amphenol.	ADC001
15ft. Work Lead	WCE0006
Coolant (Sold by the Gallon = 1 Gallon.)	TK1014
Coolant (Sold by the Box = 4 Gallons).	TK1014B
Running Gear Dual Cylinder Rack	MS1105

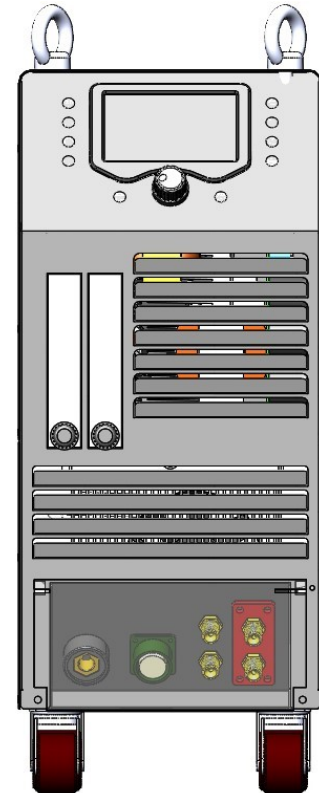

## Torch Parts

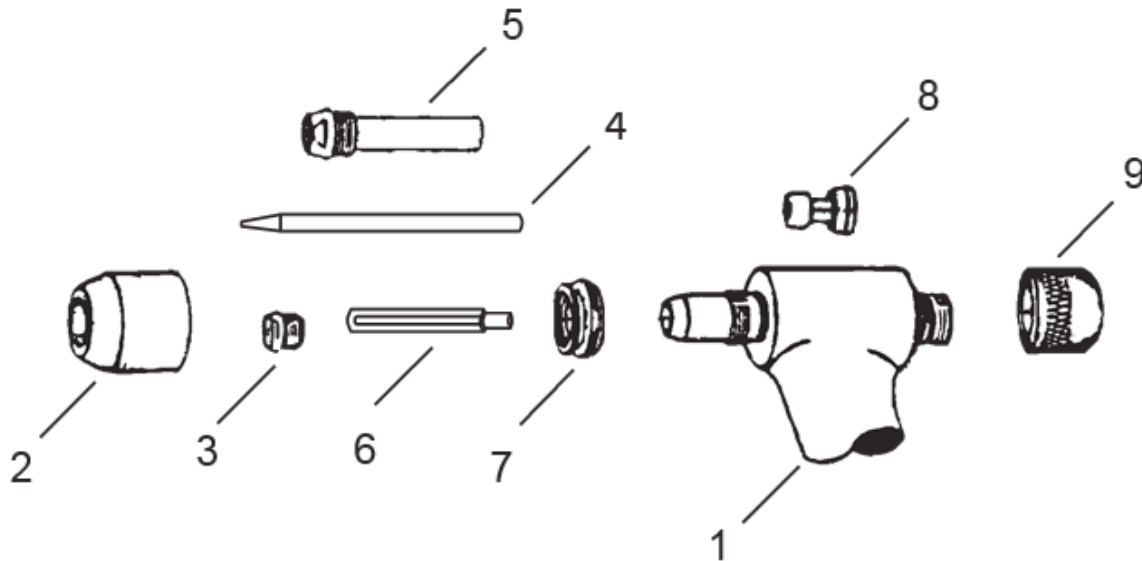

### Common Torch Consumables included in Spare Parts Kit.

ITEM NO.	PART DESCRIPTION	P-75 TORCH P75-2000	P-15 TORCH P15-2000	P-22 TORCH P22-2000
2	Shield Cup	P75-3001	P15-3001	P22-3001
3	Tip	P75-3006 (.045) 25A-Ig P75-3007 (.062) 35A-Ig P75-3008 (.081) 50A-Ig	P15-3011 (.046) 50A-ext P15-3013 (.081) 100A-ext P15-3014 (.093) 130A-ext	P22-3006 (.062) 100A-ext P22-3007 (.093) 125A-ext P22-3009 (.125) 150A-ext
4	Electrode	P75-3009 (.093) std	P15-3015 (.093) std.	P22-3010 (.187) ext.
5	Liner	N/A	N/A	P22-3011
6	Gas Distributor	P75-3013 (.093-electrode)	P15-3017	P22-3012
7	Gas Diffuser	N/A	P15-3019	P22-3015
8	Collet Assembly	P75-3017 (.093-electrode)	P15-3021	P22-3018
9	Back Cap	P75-3019 (std-electrode)	P15-3022 (std-electrode)	P22-3020 (ext-electrode)
N/S	Collar	N/A	N/A	P22-3016
N/S	O-ring (liner)	N/A	N/A	P22-3024
N/S	O-ring (internal)	N/A	N/A	P22-3025
N/S	O-ring (back-cap)	P75-3016	P15-3020	P22-3017
N/S	Gasket (shield cup)	P75-3015	P15-3018	P22-3013
N/S	Lubricant	PAW-LUBE	PAW-LUBE	PAW-LUBE
N/S	Gauge/Wrench	P75-2006 Not Included	P15-2006 Not Included	P22-2020 Not Included

NOTE: Tip ratings @ minimum electrode setback.

\*Tip maximum current rating not to exceed the maximum output of SANPAW 150PW.

## Torch Specifications

	Type	Part No.	Torch Lead Length	Current Rating	Coolant Requirements	Torch Dimensions					
						A	B	C	D	E	
P75 Torch	PWH-75 70°	P75-1000(H)	12.5 ft.	75 Amps (DCSP)	2,000 BTU/hr (504 K/Cal/hr) 1/4 gpm coolant flow @ 50 PSI (0.9 lpm @ 3.7 kg/cm <sup>2</sup> )	7-15/16"	1-11/16"	5/8"	7/8"		
		P75-1001(H)	25 ft.			(202mm)	(43 mm)	(16mm)	(22 mm)		
	PWH-75 90°	P75-1002 (H)	12.5 ft.			7-3/4"	1-11/16"	5/8"	7/8"		
		P75-1003 (H)	25 ft.			(196mm)	(43 mm)	(16mm)	(22 mm)		
	PWM-75 180° Offset	P75-1004 (H)	12.5 ft.			18-1/4"	13/16"	Min.	Max.	1-3/8"	
		P75-1005 (M)	25 ft.			(463 mm)	(21 mm)	7-1/8" (181 mm)	15" (381 mm)	(35 mm)	
15 Torch	PWH-15 70°	P15-1000 (H)	12.5 ft.	150 Amps (DCSP)	6,000 BTU/hr (1513 K/Cal/hr) 1/3 gpm coolant flow @ 50 PSI (1.25 lpm @ 3.7 kg/cm <sup>2</sup> )	8-3/4"	2-5/8"	7/8"	1-1/16"		
		P15-1001 (H)	25 ft.			(222 mm)	(67 mm)	(22 mm)	(27 mm)		
	PWH-15 90°	P15-1002 (H)	12.5 ft.			8-1/2"	2-5/8"	7/8"	1-1/16"		
		P15-1003 (H)	25 ft.			(216 mm)	(67 mm)	(22 mm)	(27 mm)		
	PWM-15 180° Offset	P15-1004 (H)	12.5 ft.			19-1/4"	1"	Min.	Max.	1-3/8"	
		P15-1005 (M)	25 ft.			(489 mm)	(25 mm)	9-1/4" (235 mm)	16-3/4" (425 mm)	(35 mm)	
P22 Torch	PWH-22 70°	P22-1000 (H)	12.5 ft.	200 Amps (DCSP)	8,000 BTU/hr (2017 K/Cal/hr) 1/2 gpm coolant flow @ 50 PSI (1.9 lpm @ 3.7 kg/cm <sup>2</sup> )	12-1/2"	3-3/16"	1-1/4"	1-3/8"		
		P22-1001 (H)	25 ft.			(318 mm)	(81 mm)	(32 mm)	(35 mm)		
	PWH-22 90°	P22-1002 (H)	12.5 ft.			12-1/4"	3-3/16"	1-1/4"	1-3/8"		
		P22-1003 (H)	25 ft.			(311 mm)	(81 mm)	(32 mm)	(35 mm)		
	PWM-22 180° Offset	P22-1004 (M)	12.5 ft.			18"	1-3/4"	Min.	Max.	1-3/8"	1-1/4"
		P22-1005 (M)	25 ft.			(457 mm)	(44 mm)	8-1/4" (209 mm)	16" (406 mm)	(35 mm)	(32mm)
PWM-22A 180° Inline	P22-1006 (H)	12.5 ft.	21"	1-3/4"	Min.	Max.	1-3/8"	1-1/4"			
	P22-1008 (M)	25 ft.	(.53 m)	(44 mm)	11-1/4" (286 mm)	19" (483 mm)	(35 mm)	(32mm)			

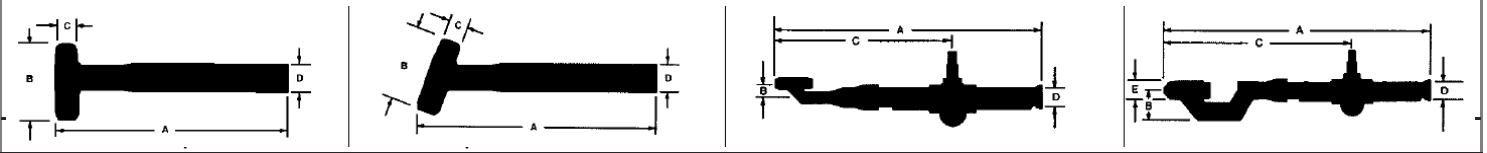

(H) designates torch with molded handle.

(M) designates torch with rack and pinion assembly.

Output @ Duty Cycle	Input	208 - 460 Volt Three Phase				
		208 VAC	240 VAC	480 VAC	575 VAC	
200A @ 35%	Power (KVA/Kw)	3 ph	9.4/9			
	Current (Amps)	3 ph	26	22.4	11.2	N/A
	Power (KVA/Kw)	1 ph	9.4/9			
	Current (Amps)	1 ph	43.7	37.8	18.9	N/A

Rated Output	Amps	0.5/200A	Contractor Control	Remote Input
	Volts	18/33V		
Output Ranges	Duty Cycle	150A @ 60%, 200A @ 35%	Current Control	Remote or Panel
	Low	0.5 - 20A	Analog Control	0 - 10 Volts DC Input
Load Volts	High	5 - 200A	Dimensions	Height: 25.49" (647.5mm)
OCV			Weight:	Width: 10.69" (271.5mm)
Input Hz				Length: 23.23" (590mm)
Flow Meters	Plasma	.5 - 3.0 SCFH (.25-1.5lpm)		79.4 lbs (36 kg)
	Shield	5 - 30 SCFH (2.5-15lpm)		

## 150PW Easy Find Guide — Build your own Handheld System.

### Plasma Arc Welding Handheld Configuration



Part No.	Description
IDU-W150PW-U1DVP	150PW
MS1105	Running Gear/Cylinder Rack



### Plasma Welding Torch (Hand Held)

Part No.	Description
P75-1000	2A - Torch, 70 degree, 12.5ft
P75-1001	2A - Torch, 70 degree, 25ft
P75-1002	2A - Torch, 90 degree, 12.5ft
P75-1003	2A - Torch, 90 degree, 25ft
P15-1000	3A - Torch, 70 degree, 12.5ft
P15-1001	3A - Torch, 70 degree, 25ft
P15-1002	3A - Torch, 90 degree, 12.5ft
P15-1003	3A - Torch, 90 degree, 25ft
P22-1000	4A - Torch, 70 degree, 12.5ft (Includes Torch Head Liner)
P22-1001	4A - Torch, 70 degree, 25ft (Includes Torch Head Liner)
P22-1002	4A - Torch, 90 degree, 12.5ft (Includes Torch Head Liner)
P22-1003	4A - Torch, 90 degree, 25ft (Includes Torch Head Liner)



### Torch Consumables Kit

Part No.	Description
P75-2000	P75 Torch Kit
P15-2000	P15 Torch Kit
P22-2000	P22 Torch Kit



### Gas Regulators (Two Required)

Part No.	Description
MS1005	Argon Regulator (Plasma Welding)
MS1006	Argon/Hydrogen Regulator (Plasma Welding)



### Gas Hose (Two Required)

Part Number	Description
MS1000	12.5ft. Gas Hose.



### Work Lead

Part Number	Description
WCE0006	15ft. Work Lead
WCE0008-25	25ft. Work Lead



### Remote Controls

Part Number	Description
FC1000	15ft. Foot Control
FC1001	25ft. Foot Control
RC1000	15ft. Remote TIG Torch On/OFF and current control. (Velcro)
RC1001	25ft. Remote TIG Torch On/OFF and current control. (Velcro)
RC1002	15ft. Remote TIG Torch On/OFF. (Velcro)

