

Plasma Welding System Setup and Operation.

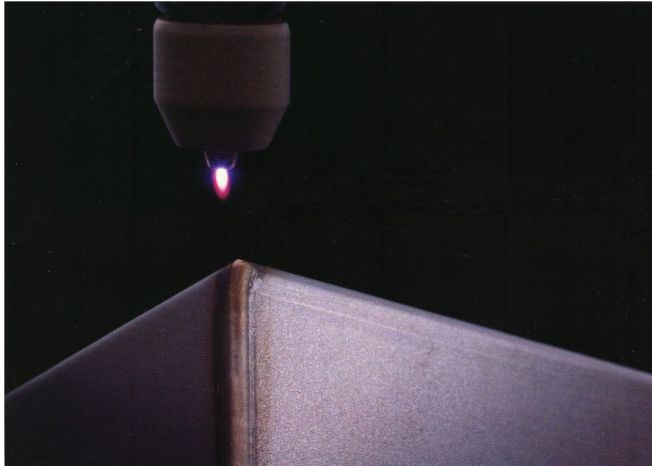

Written By Kenneth Alrick

SanRex

50 Seaview Blvd.
Port Washington, NY. 11050
516-625-1313
www.sanrexwelding.com

Folks...Plasma Welding is not TIG! Do not treat the Plasma Welding Torch as a TIG Torch. The Geometry of the Plasma Welding Torch components are set to a very tight tolerance. Altering the Geometry in anyway will result in damage and/or failure of the torch and poor welds.

Do's & Don'ts!

Torch Coolant – Never use TIG Coolant or tap water. Always use Coolant intended for Plasma Welding or Plasma Cutting Water cooled systems. The resistance of the coolant must be within the Acceptable Green range.

Comparison Chart Resistivity/Conductivity			
	Resistivity Ohms/cm @ 25°C (77°F)	Resistivity Megohms/cm @ 25°C (77°F)	Conductivity Micromhos/cm @ 25°C (77°F)
Acceptable ↑	3,000,000	3.0	.333
	1,000,000	1.0	1.00
	900,000	.90	1.11
	750,000	.75	1.35
	500,000	.50	2.00
	400,000	.40	2.75
	300,000	.30	3.33
Minimum ↓	200,000	.20	5.00
	100,000	.10	10.0
Not Acceptable ↓	90,000	.090	11.1
	75,000	.075	15.0
	50,000	.050	20.0
	25,000	.025	42.5
	10,000	.010	100.0

Damage and failure of the torch will occur if Coolant is in the Red Not Acceptable range.

TIG Coolers - Never use TIG water coolers. TIG coolers are not built with components to resist corrosion or have the cooling capacity required for plasma welding. The coolant reservoir may state noncorrosive but will leach contamination into the coolant that is conductive. In TIG applications this does not matter.

Gas supply options – Always use two Supplies each with their own Pressure Regulator set to 40 psi. Never use Regulator/Flowmeters and never “Y” off one cylinder.

Plasma Welding Gas Manifold

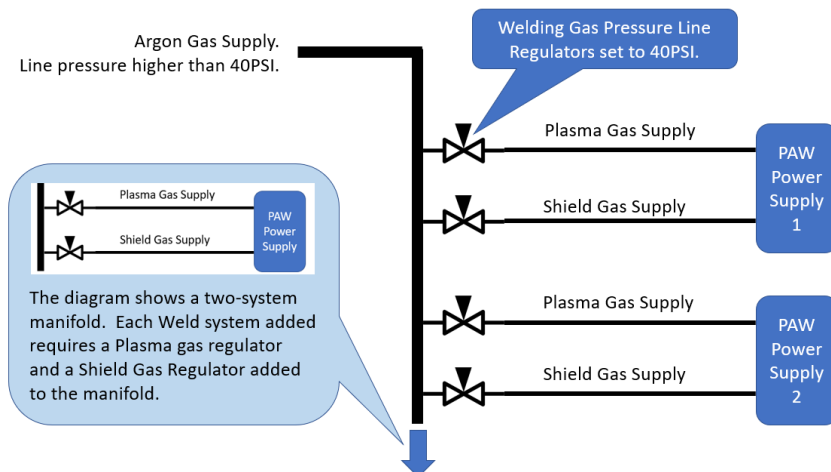

Dissimilar Plasma Welding Gas Manifold

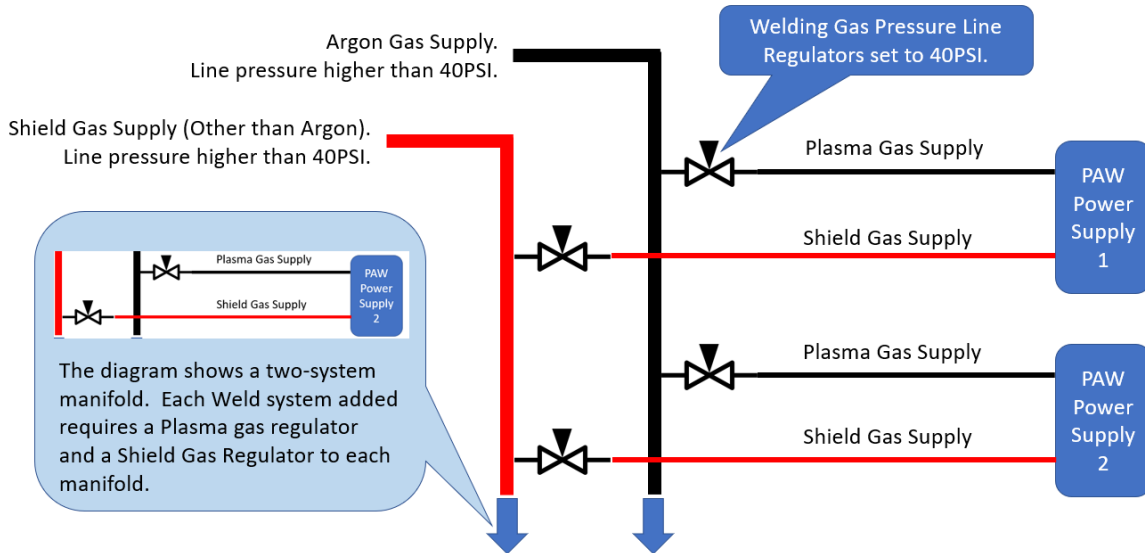

Plasma Welding with Cylinder Gas

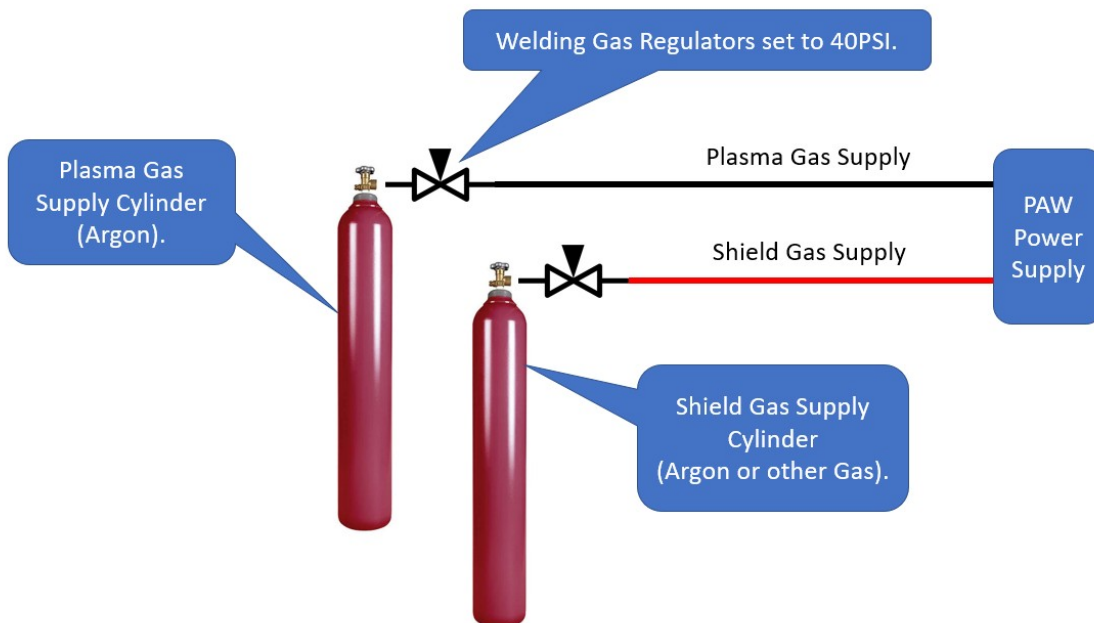

Electrode – Do not under any circumstances grind the Tungsten Electrode by hand on a bench grinder. Damage or failure of the torch will occur. The diameter and angle of the Tungsten Electrode point Geometry must match precisely the inside Geometry of the Welding TIP and be perfectly centered. Always use factory ground Tungsten Electrodes.

Not recommended, but if you must grind your own Tungsten Electrode a Precision dedicated Tungsten Grinder set to Sanrex Factory settings must be used. Electrode point sharpen to a 20 Degree included Angle, surface finish minimum 32 Microinch, remove sharp point (.015" - .025") flat. Tungsten Electrode quality is paramount with the diameter tolerance less than +/-

.005". 2% Thoriated is preferred, Lanthanated, ceriated, Zirconiated, Rare Earth Mix are acceptable but may have reduced lifetime. Do not use Pure Tungsten!

Welding TIP – The orifice diameter designates the maximum current the tip can carry. The maximum current is the pilot current plus the welding current with electrode set flush with the end of the welding tip.

Plasma Welding Torch Operation.

- Pilot Arc Ignition – Never ignite the pilot arc without pre-purge of the plasma gas for at least 1 minute. More so if in a dusty and humid environment. Any contaminants in the plasma stream during arc ignition will cause electrode and tip deterioration and cause poor welds. This also holds true when turning off the pilot arc. Always post purge for at least a minute after turning off the pilot arc.
- Always leave the pilot Arc on for the duration of the welding shift. Each pilot ignition causes electrode deterioration.

See Torch Manual for detailed instructions.

P75 Torch Assembly.

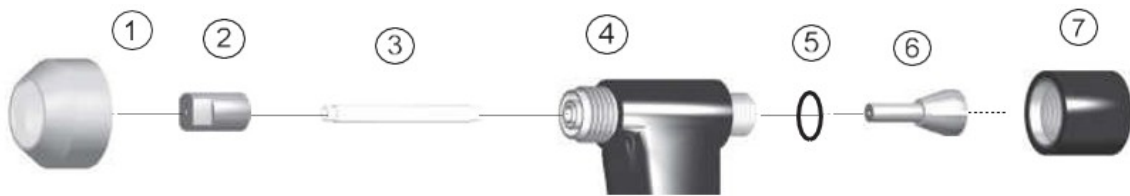

P15 Torch Assembly.



P22 & P30 Torches

The P22 & P30 Torches have an internal liner. There are two O-Rings inside the torch that seal the liner in the torch. The welding Tips thread into the liner. (See P22 Torch assembly picture.)

If an O-ring becomes damage coolant will leak into the plasma gas stream causing failure of the consumables and eventually the torch head. A black residue on the internal components is a good indication of a coolant leak most likely caused by faulty O-Rings.

Good practice when replacing the tips is to always support the liner from turning with a wrench when removing or installing tips. Excessive movement of the liner during tip replacement will cause pre-mature O-Ring failure.

P22 Torch Assembly.



1. Cup
2. Standard Tip (Keyhole Process)
3. Extended Tip (Melt-in Process)
4. Electrode
5. Liner (Red and Black O-Ring inside of
Note: NO liner in P75 or P15 Torch.)
6. Gas Distributor
7. Collar
8. Shield Gas Diffuser
9. Cup Gasket
10. Torch Head
11. Collet
12. Back Cap

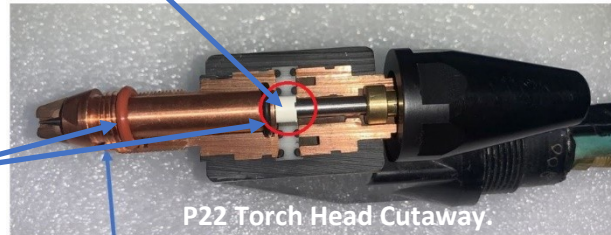

Torch).



P30 Torch Assembly.

Similar assembly as the P22 Torch.

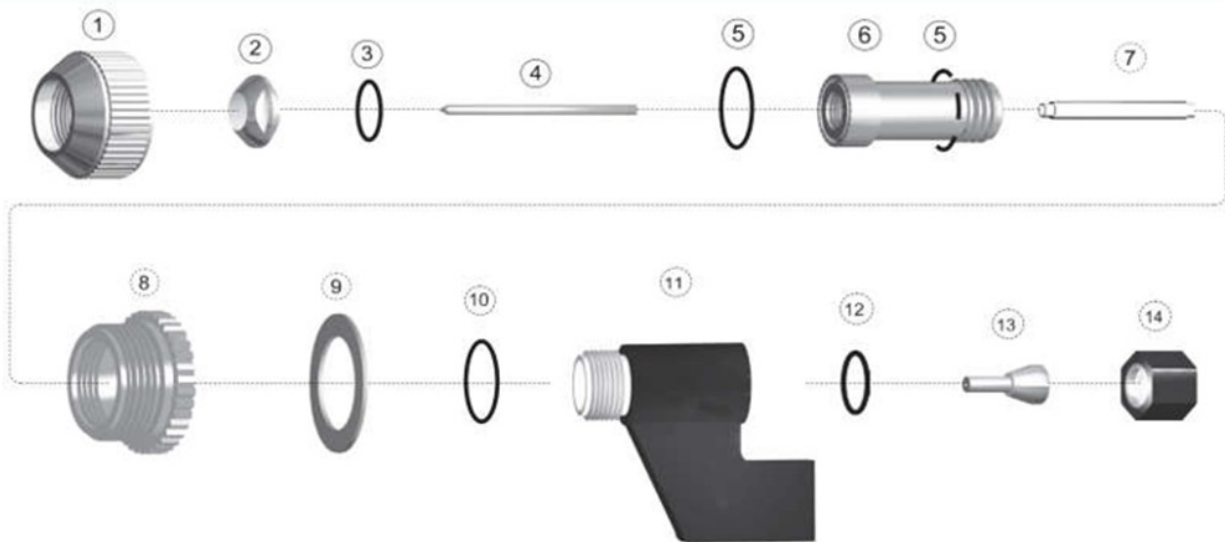

Electrode Setback

Minimum setback is defined as the electrode set flush with the end of the Welding Tip. For any other setback use setback gauge. Minimum setback will give you a TIG like Arc.

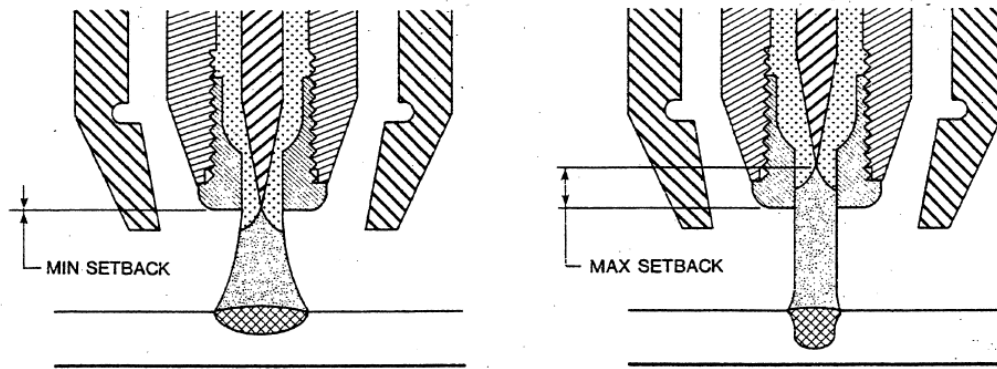

If a stiff columnated arc is desired, insert the electrode gage into the front of the torch and

loosen the electrode cap slightly. Push back on the electrode with the gage until the shoulder of the gage seats against the front of the torch. Tighten the electrode cap while holding the gage in this position. Insert the proper tip into the liner assembly and tighten moderately.

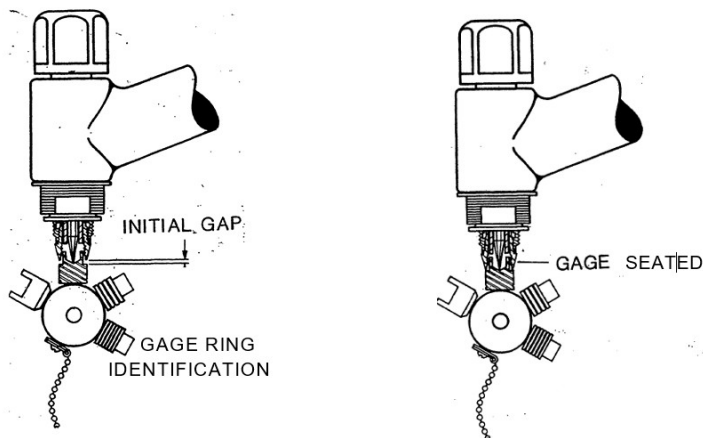

If a soft arc is desired, insert the proper tip into the liner assembly. Loosen the back cap slightly, allowing the electrode point to protrude through the orifice opening. Using a flat surface, push the electrode back until it is flush with the tip face. Tighten the back cap.

Note: Maximum Current rating of each tip is established using maximum electrode setback at the maximum plasma gas flow rates. Lower plasma gas flow rates can be used with maximum current rating of the tip if electrode setback is set to minimum.

Pre-weld



- Always purge Plasma Gas for at least 1 minutes prior to turning on the Pilot arc. Pilot arc must start in an inert atmosphere.
- Once pilot arc is on, best to leave on even when not welding.
- The pilot may dance around a little like a flame on a candle pending air currents around the application. This is OK and is expected.
- Use Argon for Plasma and Shield gas.
 - Welding SS, titanium and other exotic metals can use 95/1-5% Argon/Hydrogen for Shield gas.
 - This will brighten the weld color and remove any surface tension.
- Use pressure regulators set at 40 psi.
- Always use separate Gas supplies.
- Do not use Regulator/Flowmeters.
- Shield gas set at 15 –25 scfh.
- Use Figure 3-D as a guide to set Plasma Gas flow.
- Use Figure 3-C as a guide to set welding Current Levels for Melt In Fusion mode with Electrode set to Minimum Setback.

See Torch Owner's Manual for detailed instructions and settings.

Troubleshooting

Common causes of Poor Pilot, poor Tip life, poor Welding Arc ignition.

- Improper grinding of electrode.
 - Follow proper electrode sharpening instructions.
- Electrode discolored, Bluing in color, blue-black appearance.
 - Cause - atmosphere in contact with the electrode when hot. This can be lack of preflow and postflow gas flow and/or aspirating atmosphere into plasma stream.
- Black residue on electrode and other consumables.
 - This is caused by coolant entering the plasma stream. Most likely an internal coolant leak. The black residue is carbon build up.
- Coolant conductive. Resistivity of the coolant must be within the Acceptable Green range. Damage and failure of the torch will occur if Coolant is in the Not Acceptable range.

Comparison Chart Resistivity/Conductivity			
	Resistivity Ohms/cm @ 25°C (77°F)	Resistivity Megohms/cm @ 25°C (77°F)	Conductivity Micromhos/cm @ 25°C (77°F)
Acceptable 	3,000,000	3.0	.333
	1,000,000	1.0	1.00
	900,000	.90	1.11
	750,000	.75	1.35
	500,000	.50	2.00
	400,000	.40	2.75
	300,000	.30	3.33
Minimum	200,000	.20	5.00
	100,000	.10	10.0
Not Acceptable 	90,000	.090	11.1
	75,000	.075	15.0
	50,000	.050	20.0
	25,000	.025	42.5
	10,000	.010	100.0

Check List of Contaminated Electrode and Dirty Weld Nozzles.

1. A dark blue or black tungsten (Figure B) is a sign of moisture or oxygen getting into the plasma gas line (also called the pilot gas line). If the gas is good quality and the gas lines are leak free the tungsten should remain a gray color (Figure A) not dark blue or black. Moisture and oxygen in the gas lines deteriorate the tungsten electrode and thus the number of arc starts that the tungsten electrode can produce is reduced. This cuts down on the number of arc starts in production and decreases production.
2. Any leaks in the gas lines or fittings can allow air to be sucked into the gas system which adds oxygen and moisture to the welding gases being used. Levels of oxygen and water should be less than 5ppm. The most important gas in plasma welding is the pilot gas, also called plasma gas, most cases argon gas. The grade of argon being used should be at least 99.998% pure argon. In plasma welding if the gas is not pure it will contaminate the

tungsten electrode and turn the tungsten electrode a dark blue and black color. If the problem is very severe the discoloration will run all the way to the point of the tungsten electrode and the nozzles on the torch will clog up.



3. If your welding system is shut down over night air with oxygen and moisture will get up inside the plasma torch. Before starting to weld on the next day you need to again purge the gas lines approximately 5 to 10 minutes before starting to weld. You may want to turn the pilot gas down to a very low flow such as 0.1 liters per minute and let the gas run all night to keep the gas line clean. It will be such a low flow that it will not be of any economic importance.
4. When the pilot arc is turned off let the gas continue to flow for at least 10 to 15 seconds before turning off main power. The gas flow will keep the tungsten electrode from oxidizing until it cools down.
5. Whenever thinking about electrode life, electrode contamination, ease of arc starting and arc stability you should not forget that the exchange of ions takes place within the plasma column in both directions which is from the electrode to the work piece and from the work piece to the electrode. If impurities such as lead, sulfur, aluminum, magnesium, copper, zinc, brass, oil, grease or any other dirty elements are on or in the material being welded they will contaminate the tungsten electrode and nozzle. You then cannot count on a maximum number of welds before replacing the tungsten electrode and weld nozzle.
6. Clean the nozzle orifice with acetone or alcohol and a Q-tip. A round wooden toothpick can be used to clean the orifice of the nozzle. Weld nozzles trap contamination during welding and will need to be cleaned every time the tungsten is re-ground.
7. The pilot arc should be bright white with a light blue tint color. If the color changes to orange or purple that is a sign of contamination. Also, the pilot arc will draw back into the nozzle, which is a sign that the tungsten electrode has deteriorated.
8. The type of hose material that the pilot gas and shield gas are passed through is very important. All plastics can have moisture and oxygen that diffused through the walls of the hose material. Do not use petroleum or rubber base hoses.