

# **SANPAW 150PW**

(Model: IDU-W150PW-U1DVP)

## Operating Manual

Published May 1, 2026

Document No.: K00A0443900

Please ensure the operating manual is delivered to the final operator of the welding equipment.



**For safe and proper use, please read the operating manual  
thoroughly before using the welding equipment.**

Thank you for purchasing the SANPAW 150PW high-performance plasma welding power supply.

Before using the welding power supply, please read the operating manual carefully and use the welding power supply correctly. For all other components that would comprise a plasma welding system, such as the welding torch, gas pressure regulator, cooling water unit and other components, other than the welding power supply, refer to the operating manual for each component.

- For the purpose of safety, it is recommended that this welding equipment be installed, maintained, inspected, and repaired by appropriately qualified personnel or personnel who are very familiar with welding equipment.
- For the purpose of safety, it is recommended that this welding equipment be operated by personnel who has demonstrated substantial knowledge and skills to understand all safety precautions and instructions in the operating manual and who has demonstrated the ability to handle welding equipment safely.
- After reading the operating manual, please store it carefully in a location where it can be easily accessed and referred to by related personnel when necessary.
- Please call your local distributor, business office, or service agent if you have any questions.
- Follow all applicable laws and regulations regarding this installation and use of, for your location.

## Contents

1.1. SAFETY REGULATIONS AND REQUIREMENTS .....	6
1.2. NOTES, CAUTIONS AND WARNING ANNOTATIONS.....	6
1.3. SAFETY RECOMMENDATIONS .....	6
1.4. WELDING SYMBOLS.....	8
1.4.1. SAFETY SYMBOL LEGEND .....	8
1.5. SAFETY PRECAUTIONS .....	12
1.6. SAFE OPERATION OF THE WELDER AND PERSONAL PROTECTION .....	13
1.6.1. IMPORTANT SAFETY PRECAUTIONS.....	13
1.6.2. ELECTRIC SHOCK .....	14
1.6.3. CALIFORNIA PROPOSITION 65 WARNINGS.....	15
1.6.4. GASES AND FUMES.....	15
1.6.5. FIRE AND EXPLOSIONS .....	16
1.6.6. ARC WELDING RAYS, NOISE AND SPATTER OR SLAG .....	17
1.6.7. GAS CYLINDERS .....	18
1.7. PRECAUTIONS ON TRANSPORTATION.....	19
1.8. REFERENCE PUBLICATIONS .....	21
2. SPECIFICATIONS.....	22
2.1. POWER SUPPLY SPECIFICATIONS .....	22
2.2. INSTALLATION ENVIRONMENT .....	23
3. INSTALLATION .....	24
3.1. PREPARATION PRIOR TO INSTALLATION .....	24
3.1.1. CHECKING THE ACCESSORIES .....	24
3.1.2. POWER-SUPPLY SYSTEM.....	24
3.1.3. REFERENCE CABLE SIZE.....	24
3.1.4. Coolant Recirculator System.....	24
3.2. INSTALLATION.....	25
3.3. WIRING CONNECTION OF INPUT VOLTAGE .....	26
3.3.1. WIRING THE SUPPLIED INPUT CABLE .....	26
3.4. WIRING TO THE POWER DISTRIBUTION PANEL .....	29
3.5. CONNECTING THE ACCESSORIES .....	30
3.5.1. WIRING OF REMOTE CONTROLLER OUTLET .....	32
3.5.2. CONNECTION TO EXTERNAL OUTPUT SIGNAL TERMINAL BLOCK .....	33
3.5.3. OUTPUT CABLE, GAS, COOLING WATER UNIT CONNECTIONS .....	35
4. OPERATION PROCEDURES .....	38
4.1. USER INTERFACE OVERVIEW AND OPERATION.....	38
4.2. WELDING PARAMETER DESCRIPTIONS .....	40
4.3. WELDING PROCESSES.....	42

4.3.1. PILOT OUTPUT.....	42
4.3.2. MAIN OUTPUT .....	43
4.3.2.1. 2T MODE (WITH SLOPE).....	43
4.3.2.2. 4T MODE (WHEN P20: 4T MODE SETTING IS ON).....	44
4.3.2.3. REPEAT MODE .....	45
4.3.2.4. SPOT MODE.....	46
4.4. PULSE MODE .....	47
4.4.1. PULSE MODE .....	47
5. FUNCTIONS .....	48
5.1. FUNCTION FOR AUTOMATION .....	48
5.2. SAVE/LOAD FUNCTIONS .....	51
5.2.1. MACH MEM Function.....	51
5.2.2. USB MEM Function .....	52
6. INTERNAL PARAMETER SETTING.....	53
6.1. INTERNAL PARAMETER DESCRIPTION .....	53
6.1.1. PEAK CURRENT MAXIMUM SETTING .....	53
6.1.2. 2T SLOPE FUNCTION.....	54
6.1.3. 4T/4TS/REPEAT/SEQ.....	55
6.1.4. PULSE SIGNAL OUTPUT.....	56
6.1.5. OK TO MOVE CURRENT DETECT OUTPUT.....	56
6.1.6. PILOT-CUR DETECT SIGNAL OUTPUT .....	56
6.1.7. PILOT GAS PRE-FLOW.....	56
6.1.8. ERROR SIGNAL OUTPUT LOGIC.....	57
7. DAILY INSPECTION .....	57
8. Warning .....	59
8.1. Abnormality .....	59
8.2. ACTIONS FOR ABNORMAL OPERATION.....	60
9. OUTLINE DRAWING .....	61
10. CONNECTION DIAGRAM .....	62
11. APPENDIX A .....	64
11.1. AUTOMATION I/O RELATIONSHIP SUMMARY .....	64
12. Parts List & Exploded View.....	65
13. Quick Start Menu Guide.....	69

## SAFETY PRECAUTIONS

*Please read this operating manual thoroughly before utilizing the equipment.  
Wherever welding equipment is used, safety is always our concern.  
PROTECT yourself and others.*

### 1.1. SAFETY REGULATIONS AND REQUIREMENTS

Throughout this manual, notes, cautions, danger, attention and warnings are used to highlight important information. These highlights are categorized as follows:

### 1.2. NOTES, CAUTIONS AND WARNING ANNOTATIONS

#### NOTE



An operation, procedure, or background information which requires additional emphasis or is helpful in efficient operation of the system.

#### CAUTION



A procedure which, if not properly followed, may cause damage to the equipment.

#### WARNING



A procedure which, if not properly followed, may cause injury to the operator or others in the operation of the equipment.

#### DANGER



Procedures, which if not properly followed, may lead to serious injury or death.

### 1.3. SAFETY RECOMMENDATIONS

**CAUTION**



For the purpose of safety, it is recommended that this welding equipment be installed, maintained, inspected, and repaired by appropriate qualified person or persons who are well familiarized with welding equipment.

**CAUTION**



As for safety training, it is recommended to avail yourselves of various seminars and qualifying examinations for welding engineers and welding technicians sponsored by the American Welding Society, the headquarters or branch offices of welding societies or associations concerned.

**CAUTION**



For the purpose of safety, it is recommended that this welding equipment should be operated by persons who have sufficient knowledge and skill to understand all safety precautions and instructions in the Operating Manual and to be able handle the equipment safely.

**CAUTION**



After reading this Operating Manual, please store it carefully in a location with a guarantee that it is made accessible for all personnel associated with the equipment.







**NOTE**











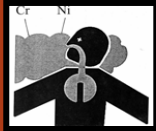



Please call your local distributors, business offices, or service agents if you have any questions

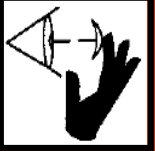

## 1.4. WELDING SYMBOLS

### 1.4.1. SAFETY SYMBOL LEGEND

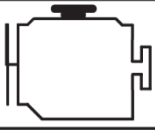
SYMBOL	SOURCE OF HAZARD	HAZARD	HOW TO AVOID
	Welding Electrode	Electric Shock	Don't weld on painted parts. Remove the surface coating before you begin welding. Keep your face away from the welding plume.
	Wiring	Electric Shock	Protect welding cables from sparks, hot metal, open flames, sharp edges, oil, and grease. Do not use cables with frayed, cracked or bare spots in the insulation. Learn all you can about safety. Your employer must provide safety training.
	Welding Arc	Arc Rays	Required protection varies with time of exposure, distance from source, and shielding used. Follow recommended procedures in AWS F2.1
	Engine Fuel	Fire	Develop adequate procedures, and use proper equipment to do the job safely. When required obtain a Hot-Work Permit (See NFPA 51B). If relocation is not possible, protect combustibles with fire resistant covers
	Welding Fumes and Gases	Fumes and Gases	Keep your head out of the fumes. Do not breathe the fumes. Use enough ventilation or exhaust at the arc, or both, to keep fumes and gases from your breathing zone and general area
	Welding Electrode and Wiring	Electric Shock	Read all instructions, labels, and installation manuals before installing, operating, or servicing the equipment. Train all personnel involved in welding operations to observe safe electrical work practices according to OSHA 1910.332. Do not touch live electrical parts.

SYMBOL	SOURCE OF HAZARD	HAZARD	HOW TO AVOID
	Chromium and Nickel Fumes	Welding Fumes	<p>Do not breathe fumes and gases. Keep your head out of the fumes.</p> <p>Use enough ventilation or exhaust at the arc or both to keep fumes and gases from your breathing zone and general area</p>
	Hazard Distances	Ultraviolet Radiation	<p>Maintain proper distances from the Arc Ray.</p> <p>Review the "Safety and Health Fact Sheet No. 26" from the AWS for recommendations.</p>
	Falling Objects	Falling Objects	<p>Be certain that material being welded or cut is secured from falling.</p> <p>Do not permit loose objects near the edge of overhead structures</p>
	Confined Space	Fire, Exposure to Hazardous Air Contaminants	<p>Determine if special training or a permit is required to enter the space.</p> <p>Open all covers and secure them from closing.</p> <p>Test atmosphere for:</p> <ul style="list-style-type: none"> <li>(1) suitable oxygen content</li> <li>(2) combustibles or reactives</li> <li>(3) toxics</li> </ul>
	Sparks, Radiation, Hot Metal, Slag, Heat	Electrical, Thermal	<p>Wear a helmet with filter lens and cover plate that complies with ANSI Z87.1 for protection from radiant energy, flying sparks, and spatter.</p> <p>According to ANSI Z49.1 and OSHA 29 CFR 1910.252, "Helmets and hand shields shall protect the face, forehead, neck, and ears PPE</p>
	Hot Metal, Slag, Arc Rays, Hot Work Piece	Thermal	<p>Use approved helmets or hand shields that provide protection for the face, neck, and ears, and wear a head covering.</p> <p>Wear approved safety goggles or safety glasses with side shields, even under your helmet.</p> <p>Wear dry, hole-free insulating gloves.</p>

SYMBOL	SOURCE OF HAZARD	HAZARD	HOW TO AVOID
	Optical Radiation and Arc Heat	Thermal	Establish a written policy documenting general safety requirements for the wearing of contact lenses. Conduct an eye hazard evaluation in the workplace
	Cuts, Scrapes, Heat, Flames, Molten Metal, Wet Gloves, Insulation Failure	Mechanical, Thermal, Electrical	Gloves should be: Dry and moisture resistant. In good condition, no holes or tears. Flame resistant. Electrically and thermally insulated to suit the process.
	Coating of Steel	Fumes and Gases	Obtain the Material Safety Data Sheets (MSDSs) for all materials used. Read and understand the specification for coating type and coating weights. Find out what hazardous materials are present or might be given off by the coating when it is exposed to the arc of high temperatures
	Reactive Force from Tools, Tool Jammed or Coming Loose	Mechanical	Wear proper head, eye and hand protection. Use face shields, safety glasses, and goggles as appropriate. Inspect tools before use. Never use a tool that is in poor or faulty condition. Keep all tools in good condition.
	Engine-Driven Generators, power source Equipment	Health Hazard	Reduce the intensity of the source. Shield the source where practical. Use engineering control methods, such as room acoustics, to control noise.
	Place Body Between Welding Electrode and Work Cables	Electric & Magnetic Fields	Do not place your body between the welding electrode and work cables. Route cables on the same side of your body. Route the welding cables close together. Secure them together with tape or cable ties.

SYMBOL	SOURCE OF HAZARD	HAZARD	HOW TO AVOID
	Any Coatings on Base Metal, Weld Process	Fumes and Gases	<p>Keep your head out of the fumes. Do not breathe the fumes.</p> <p>Use enough ventilation or exhaust at the arc, or both, to keep fumes and gases from your breathing zone and general area</p>
	Welding & Cutting	Toxic Fumes, Electric Shock	<p>Be alert, aware, and focused on the job and the work area; notice any changing conditions.</p> <p>Wear and use only the correct, approved equipment for the specific job; be sure it is properly installed and used</p>
	Welding or its Allied Processes	Pneumatic, Electrical, Gases, Liquid	<p>Employers must develop a written lockout/tagout program and procedure.</p> <p>Employees must be trained in these procedures, as well as the purpose and methods of lockout/tagout.</p>

## 1.5. SAFETY PRECAUTIONS

---

### ATTENTION



**FOR PROPER USE, PLEASE READ THIS OPERATING MANUAL THOROUGHLY PRIOR TO UTILIZING THE WELDING MACHINE.**

---

The safety precautions described in this Operating Manual will give you the information necessary for you to handle and operate the equipment safely and prevent any hazard or damage to you or others.

Although this welding equipment is designed and manufactured taking into account all possible scenarios, be sure to observe the safety precautions in this Operating Manual when operating this welding equipment. Not doing so may cause harm to the operator or others, resulting in death or serious injury.

Improper use of the equipment may cause various levels of damage. In this Operating Manual, such damages are classified into two ranks by combination of attention attracting symbols and signal for the purpose of warning indications. These attention attracting symbols and signal terms have the same meanings as those for warning labels on the equipment.

### CAUTION



**PROCEDURES, IF NOT PROPERLY FOLLOWED, MAY CAUSE A RISK TO OPERATORS RESULTING IN MEDIUM OR SLIGHT INJURY AND/ OR DAMAGE**

---

Serious or light injury includes loss of sight, (high temperature and/or low temperature) burns, electric shock, bone fracture, and poisoning which may lead to hospitalization or long-term hospital stay for treatment. Further, medium and slight injuries include burns, and electric shock, which do not require hospitalization or long-term visit to hospital stays for treatment. Damage to objects denotes widespread damage to property or equipment.

---

### DANGER



**PROCEDURES NOT PROPERLY FOLLOWED, MAY LEAD TO DEATH OR SERIOUS INJURY.**

---

# 1.6. SAFE OPERATION OF THE WELDER AND PERSONAL PROTECTION

## 1.6.1. IMPORTANT SAFETY PRECAUTIONS

To prevent serious injury to the operator or others, be sure to observe the following:

**CAUTION**



Never allow any unqualified person to enter the surrounding area of this welding equipment or the welding area inadvertently.

**CAUTION**



Those who use heart pacemakers should not enter the surrounding area of this welding equipment while in operation or the welding area without permission of your doctor.

**DANGER**



Welding equipment during energizing produces a magnetic field in the surrounding area which adversely affects the operation of such pacemakers

**CAUTION**



Although this welding equipment is designed and manufactured taking into account safety adequately, be sure to observe the safety precautions in this Operating Manual when operating this welding equipment.

**CAUTION**



For the purpose of safety, it is recommended that this welding equipment should be installed, maintained, inspected, and repaired by appropriately qualified personnel or persons who are well familiarized with welding equipment

**DANGER**



Not doing so may cause fatal injury to the operator or others, resulting in death or serious injury.

**CAUTION**



Perform any work of power source on the input side, select any location, handle and store and pipe high pressure gases, store work pieces welded, and treat wastes in accordance with legislations and/or regulations, and your company's standard.

**CAUTION**



For the purpose of safety, it is recommended that this welding equipment should be operated by persons who have sufficient knowledge and skill to understand all safety precautions and instructions in the Operating Manual and to operate the equipment safely.

**DANGER**



**CAUTION**



Do not use this welding equipment for applications other than welding.

## 1.6.2. ELECTRIC SHOCK

To prevent electric shock, be sure to observe the following precaution:

**DANGER**



Touching any parts that are electrically “live” or “hot” may cause fatal electric shock or burns.

**CAUTION**



Have a qualified electrician connect the Welding Power Supply. Check the enclosure, base metal and jig that they are electrically connected in accordance with local regulations. (Electrical Facilities Technical Standards)

**CAUTION**



Before installing, maintaining, or inspecting this welding equipment, leave the equipment off for over 5 minutes after turning off power supply at the distribution panel switch.

**CAUTION**



Capacitors built into the unit may be electrically charged even after the power has been switched off.

**CAUTION**



Before performing any work, make sure that no charging voltage is applied to such parts.

**DANGER**



Do not use cables which have insufficient capacity, are damaged, or any conductor is exposed. Tighten cable connections securely and insulate properly.

**CAUTION**



Tighten cable connections securely and insure that they are insulated properly.

**CAUTION**



Do not operate the welding equipment with its cover or enclosure loose or removed.

**DANGER**



**CAUTION**



Do not wear damaged, torn or wet gloves. Always wear dry insulated gloves.

**CAUTION**



Use a lifeline harness when performing work at any high elevations.

**CAUTION**



Carry out maintenance and inspection periodically and perform it after the repair of any and all damaged parts.

**DANGER**



Turn off both the Mains ON/OFF switch on equipment and the distribution panel switch when not in use.

### 1.6.3. CALIFORNIA PROPOSITION 65 WARNINGS

**WARNING**



This product produces fumes or gases which contain chemicals known to the State of California to cause birth defects and, in some cases, cancer. (California Health & Safety Code Section 25249.5 et seq.)

**WARNING**



This product can expose you to chemicals including lead, which is known to the State of California to cause cancer and birth defects or other reproductive harm. For more information refer to [www.P65Warnings.ca.gov](http://www.P65Warnings.ca.gov).

### 1.6.4. GASES AND FUMES

**To protect you and others from fumes and gases produced during the welding processes, use safeguards.**

**CAUTION**



Inhalation of gases and fumes produced during the welding processes can be dangerous and hazardous to your health.

**DANGER**



Welding in confined spaces may cause oxygen deficiency, resulting in suffocation.

**CAUTION**



When welding in confined spaces, ensure that the welding area is adequately ventilated, wear a respirator, and perform the welding work under supervision.

**CAUTION**



Never perform the welding work in the vicinity of degreasing, washing, and spraying operations. Doing so may cause harmful gases.

**DANGER**



**CAUTION**



When welding a coated steel plate, ensure that the welding area is adequately ventilated or wear a respirator. Welding coated steel plates may produce harmful fumes or gases.

**DANGER**



**CAUTION**



To prevent gas poisoning or suffocation, use local ventilating facilities set forth in legislations or Regulations (Industrial Safety and Health Law and Ordinance on Prevention of Hazards Due to Dusts and/or Fumes) or wear a respirator.

**DANGER**



## 1.6.5. FIRE AND EXPLOSIONS

To prevent fire, explosion, or rupture, be sure to observe the following precautions.

**CAUTION**



Spatter or hot base metals produced during and immediately after the welding processes may cause fire.

**DANGER**



**DANGER**



Do not weld in the vicinity of flammable gases.

**CAUTION**



Keep hot base metals immediately after the welding processes away from combustibles.

**CAUTION**



Poor connections of cables or defective contacts in any current path on the base metal such as a steel frame may cause overheating due to conducting current and may resulting in a fire.

**CAUTION**



When welding ceilings, floors or walls, remove combustibles hidden adjacent to them.

**DANGER**



**CAUTION**



Tighten cable connections securely and insulate them.

**DANGER**



Explosion can be caused by the welding arc produced on containers that may have held combustibles such as gasoline.

**CAUTION**



Connect work lead so that it is positioned as close to the part welded as possible.

**CAUTION**



Rupture can be caused by welding enclosed tanks or pipes.

**CAUTION**



Do not weld a gas pipe that may have held any gas or an enclosed tank or pipe

**CAUTION**



Keep combustibles away from scattered welding spatter. Cover combustibles that cannot be removed with incombustible shields.

**DANGER**



**CAUTION**



Have a fire extinguisher handy in the vicinity of the welding area in preparation for emergency.

## 1.6.6. ARC WELDING RAYS, NOISE AND SPATTER OR SLAG

To protect you and others from arc rays, scattered spatter or slag, and loud noise produced during the welding processes, use safeguards.

**CAUTION**



Arc rays can cause your eyes irritation and burn your skin.

**CAUTION**



To protect your eyes from spatter or slag, wear goggles.

**DANGER**



**CAUTION**



Wear safeguards including gauntlet type of welding safety gloves, long-sleeved clothing, leggings and spats, and leather aprons, etc.

**CAUTION**



Scattered welding spatter or slag will damage your eyes and cause burns.

**CAUTION**



Prevent gas cylinders from being exposed to welding arc and spatter generated from the welding torch.

**DANGER**



**CAUTION**



To protect others' eyes from arc rays, place protective booths, screens, or shields around the work area.

**CAUTION**



Loud noise can cause hearing loss.

**CAUTION**



Never touch the gas cylinder with the electrode.

**CAUTION**



To perform or monitor welding work, wear an eye protector with filter lenses providing sufficient scale number, or a welding face shield

**CAUTION**



In case when noise levels exceed safe levels, wear protective earplugs and/or earmuffs.

## 1.6.7. GAS CYLINDERS

**To prevent the turnover of gas cylinder or the rupture of gas flow regulator, be sure to observe the following precautions**

**CAUTION**



Turnover, tipping or falling gas cylinder may cause injury to the operator or others. Cylinders should properly secured.

**CAUTION**



Read and follow all warnings, safety precautions, and instructions in the Operating Manual which is supplied with the gas flow regulator prior to use.

**CAUTION**



If gas cylinder containing a gas at high pressure is handled improperly, high pressure gas may flow out, causing injury to the operator or others.

**CAUTION**



Fix the gas cylinder on a special-purpose holder or rack.

**DANGER**



**CAUTION**



Gas cylinder shall not be exposed to high temperature.

**CAUTION**



Handle the gas cylinder according to legislations or regulations and your company's standards.

**DANGER**



**DANGER**



**CAUTION**



Keep your face away from the gas cylinder outlet when opening the gas cylinder valve.

**CAUTION**



Use a gas flow regulator of the proper size and is suited for the shielding gas type being used.

**CAUTION**



Be sure to attach a protective cap to the gas cylinder outlet when not in use.

**DANGER**



**CAUTION**







Prevent the gas cylinder from being exposed to welding arc generated from the welding torch.

## 1.7. PRECAUTIONS ON TRANSPORTATION

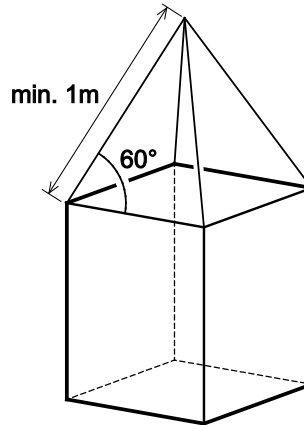
**In order to prevent damage and accidents when transporting the power supply, be sure to observe the following precautions.**

※ Carefully observe the rules in the following diagram when slinging the welding equipment.



	<h3>CAUTION</h3>		<ul style="list-style-type: none"> <li>◆ Have a qualified person perform the work for transport such as slinging the welding equipment, crane operations, and operating a forklift.</li> <li>◆ Do not transport the welding equipment directly with a forklift or by other means.</li> <li>◆ Before transport, check the weight of the welding power supply and select a wire rope that is appropriate for that weight.</li> <li>◆ Use eye bolts for transport and check that the eye bolts have been tightened before transport.</li> <li>◆ During transport, do not directly sling the welding power supply with rope. Otherwise the enclosure may deform, causing a breakdown.</li> </ul>
			<ul style="list-style-type: none"> <li>◆ Remove all of the wiring and accessories before transport.</li> <li>◆ Do not put objects on the top of the welding power supply or allow people to get on top of it.</li> </ul>



The product and the required symbols displayed on its packaging indicate that the product must not be disposed of in the same manner as regular household garbage. In order to recycle waste electrical and electronic equipment, it is the responsibility of the user to dispose of the waste equipment by delivering it to a designated collection point. When disposing of waste equipment, sorting it and having it collected and recycled is beneficial for protecting natural resources and leads to the establishment of methods of recycling that protect human health and the environment. For details on waste equipment collection points for recycling, inquire with the recycling facilities for your region or the distributor where the product was purchased.

PAGE LEFT INTENTIONALLY BLANK

## 1.8. REFERENCE PUBLICATIONS

Refer to the following standards or their latest revisions for more information:

1. OSHA, SAFETY AND HEALTH STANDARDS, 29CFR 1910, obtainable from the Superintendent of Documents, U.S. Government Printing Office, 732 N. Capital St NW, Washington, D.C. 20402
2. ANSI Standard Z49.1, SAFETY IN WELDING AND CUTTING, updated 2010, obtainable from the American Welding Society, 8669 NW 36<sup>th</sup> Street, Miami, FL 33166-6672
3. NIOSH, SAFETY AND HEALTH IN ARC WELDING AND GAS WELDING AND CUTTING, obtainable from the Superintendent of Documents, U.S. Government Printing Office, Washington, D.C. 20402
4. ANSI Standard Z87.1, SAFE PRACTICES FOR OCCUPATION AND EDUCATIONAL EYE AND FACE PROTECTION, obtainable from American National Standards Institute, 25 West 43<sup>rd</sup> Street, Fourth Floor, New York, NY 10036
5. ANSI Standard Z41.1, STANDARD FOR MEN'S SAFETY-TOE FOOTWEAR, obtainable from the American National Standards Institute, 25 West 43<sup>rd</sup> Street, Fourth Floor, New York, NY 10018
6. ANSI Standard Z49.2, FIRE PREVENTION IN THE USE OF CUTTING AND WELDING PROCESSES, obtainable from American National Standards Institute, 25 West 43<sup>rd</sup> Street, Fourth Floor, New York, NY 10018
7. AWS Standard A6.0, WELDING AND CUTTING CONTAINERS WHICH HAVE HELD COMBUSTIBLES, obtainable from American Welding Society, 8669 NW 36<sup>th</sup> Street, Miami, FL 33166-6672
8. NFPA Standard 51, OXYGEN-FUEL GAS SYSTEMS FOR WELDING, CUTTING AND ALLIED PROCESSES, obtainable from the National Fire Protection Association, 1 Batterymarch Park, Quincy, MA 02169
9. NFPA Standard 70, NATIONAL ELECTRICAL CODE, obtainable from the National Fire Protection Association, 1 Batterymarch Park, Quincy, MA 02169
10. NFPA Standard 51B, CUTTING AND WELDING PROCESSES, obtainable from the National Fire Protection Association, 1 Batterymarch Park, Quincy, MA 02169
11. CGA Pamphlet P-1, SAFE HANDLING OF COMPRESSED GASES IN CYLINDERS, obtainable from the Compressed Gas Association, 14501 George Carter Way, Suite 103, Chantilly, VA, 20151
12. CSA Standard W117.2, CODE FOR SAFETY IN WELDING AND CUTTING, obtainable from the Canadian Standards Association, Standards Sales, 178 Rexdale Boulevard, Rexdale, Ontario, Canada M9W 1R3
13. NWSA booklet, WELDING SAFETY BIBLIOGRAPHY obtainable from the National Welding Supply Association, 1900 Arch Street, Philadelphia, PA 19103
14. American Welding Society Standard AWSF4.1, RECOMMENDED SAFE PRACTICES FOR THE PREPARATION FOR WELDING AND CUTTING OF CONTAINERS AND PIPING THAT HAVE HELD HAZARDOUS SUBSTANCES, obtainable from the American Welding Society, 8669 NW 36<sup>th</sup> Street, Miami, FL 33166-6672
15. ANSI Standard Z88.2, PRACTICE FOR RESPIRATORY PROTECTION, obtainable from American National Standards Institute, 25 West 43<sup>rd</sup> Street, Fourth Floor, New York, NY 10018

## 2. SPECIFICATIONS

### 2.1. POWER SUPPLY SPECIFICATIONS

Parameters		SANPAW 150PW			
Model		IDU-W150PW-U1DVP			
Description		Plasma welding			
Main	Rated Output	200A @ 33.0V, 35% Duty cycle			
	Output Current @ Output Voltage	Input Power	60% Duty	100% Duty	
		208V, 240V, 480V, 1 $\phi$ , 3 $\phi$	150A @ 31.0V	115A @ 30V	
	Open Circuit Voltage (OCV)	71V at input 208VAC, 240VAC, 480VAC, 1 $\phi$ input 71V at input 208VAC, 240VAC, 480VAC, 3 $\phi$ input			
Output Range	DC 0.5 to 200 A, (Low range 0.5 – 20A, High range 5 – 200A)				
Pilot	Rated Output	20A @ 45.0V, 100% Duty cycle			
	Output Current @ Output Voltage	Input Power	100% Duty		
		208V, 240V, 480V, 1 $\phi$ , 3 $\phi$	20A @ 45.0V		
	Open Circuit Voltage (OCV)	103V at input 208VAC, 240VAC, 480VAC, 1 $\phi$ input 103V at input 208VAC, 240VAC, 480VAC, 3 $\phi$ input			
Output Range	DC 1 to 20 A				
Input Voltage /Current at Rated Output		Single-Phase		Three-Phase	
		Voltage (V)	Current (A)	Voltage (V)	Current (A)
		208	43.7	208	25.9
		240	37.8	240	22.4
	480	18.9	480	11.2	
Maximum Output Amperes (Amps)		200			
Maximum Output Volts (Volts)		40.0			
Maximum Pilot Output Amperes (Amps)		20			
Maximum Pilot Output Volts (Volts)		60.0			
KVA		9.4			
KW		9.0			
Input					
Input Voltage		208V, 240V, 480VAC 1-phase, Automatic Linking. 208V, 240V, 480VAC 3-phase, Automatic Linking.			
Line Frequency		50/60 Hz			
Line Volts Compensation		+/-10%			
Cooling Method		Forced Air Cooling			
Weight		79.4 lbs. (36 kg)			
Dimensions [H x W x L]		26.77x 9.84 x 23.63 in. (680 x 250 x 600 mm)			

Recirculator Capacity	3.2 Gal. (12 liter)
Coolant Specification: Maximum conductivity 10 $\mu$ S/cm, PH 6-8, resist freezing to $-12^{\circ}\text{C}$ ( $+10^{\circ}\text{F}$ ). Composition: Deionized water 70%, propylene glycol 30%.	

Comparison Chart			
Resistivity/Conductivity			
	Resistivity Ohms/cm @25°C (77°F)	Resistivity Megohms/cm @25°C (77°F)	Conductivity Micromhos/cm @25°C (77°F)
Acceptable	3,000,000	3.00	0.333
	1,000,000	1.00	1.00
	900,000	0.90	1.11
	750,000	0.75	1.35
	500,000	0.50	2.00
	400,000	0.40	2.75
	300,000	0.30	3.33
	200,000	0.20	5.00
Minimum	100,000	0.10	10.0
Not Acceptable	90,000	0.090	11.1
	75,000	0.075	15.0
	50,000	0.050	20.0
	25,000	0.025	42.5
	10,000	0.010	100.0

SanRex continuously strives to produce the best product possible and therefore reserves the right to change, improve or revise the specifications or design of this or any product without prior notice. Such updates or changes do not entitle the buyer of equipment previously sold or shipped to the corresponding changes, updates, improvements, or replacement of such items.

The values specified in the previous table are optimal values, your values may differ. Individual equipment may differ from the above specifications due to in part, but not exclusively, to any one or more of the following: variations or changes in manufactured components, installation location and conditions and local power grid supply conditions.

## 2.2. INSTALLATION ENVIRONMENT

Operating Temperature	$-10^{\circ}\text{C}$ to $40^{\circ}\text{C}$ ( $14^{\circ}\text{F}$ ~ $104^{\circ}\text{F}$ )
Storage Temperature	$-25^{\circ}\text{C}$ to $55^{\circ}\text{C}$ ( $-13^{\circ}\text{F}$ ~ $131^{\circ}\text{F}$ )
Relative Humidity	90% RH or less at $20^{\circ}\text{C}$ or less ( $68^{\circ}\text{F}$ ) 85% RH or less at over $20^{\circ}\text{C}$ to $40^{\circ}\text{C}$ ( $104^{\circ}\text{F}$ )
Dust	The air should not contain excessive levels of dust, oxidizing or corrosive gases, or corrosive substances

# 3. INSTALLATION

## 3.1. PREPARATION PRIOR TO INSTALLATION

### 3.1.1. CHECKING THE ACCESSORIES

First check the accessories.

- DINSE connector (male) x 1ea
- Coolant x 3 Gal. Note: Only included when ordering a system package.
- Operating Manual (this manual) x 1ea

### 3.1.2. POWER-SUPPLY SYSTEM

Before using the welding power supply, please prepare the following required power-supply system.

System Capacity	9.4 kVA or higher		
Input Voltage	208/240 VAC	208/240 VAC	480 VAC
Phases	Single-phase	3-phase	
Frequency	50/60 Hz		
Fuse Capacity	60 A	40 A	20 A

※ Install a distribution panel (with built-in fuse) for each welding power supply unit.

### 3.1.3. REFERENCE CABLE SIZE

If not using supplied Primary cable, please prepare cables thicker than the sizes listed below to connect to the welding power supply.

Input Cable	5.2 mm <sup>2</sup> or larger (AWG 10 = 5.2 mm <sup>2</sup> )
Ground Conductor	5.2 mm <sup>2</sup> or larger (AWG 10 = 5.2 mm <sup>2</sup> )
Output Cable	35 mm <sup>2</sup> or larger (AWG 2 = 33.6 mm <sup>2</sup> )

※ To prevent unusual decreases in the input power supply voltage and to ensure stable welding, use a power-supply system capacity and cable size that are as large as possible.

※ Input cable clamp is adjustable to cable diameter from 3/4"(19.0mm) to 1-1/8"(28.6mm).

### 3.1.4. Coolant Recirculator System

Fill Coolant reservoir with recommended Coolant. Do not overfill.

- Coolant Requirements - Specification: Maximum conductivity 10 μS/cm, PH 6-8, resist freezing to -12 °C (+10 °f). Composition: Deionized water 70%, propylene glycol 30%.

Priming the pump for the first time.

1. Properly connect the coolant connection and gas connection of the Torch.

2. Fill the coolant tank with coolant (note that the coolant level should be between MIN & MAX).
3. (The most important point) The torch should be placed below the coolant level in the coolant tank (such as on the ground).
4. The pump is below the coolant tank. The coolant will self-prime the pump.  
Note: May need to loosen the Negative and Positive lead to allow coolant to flow. Also may need to turn the 150PW ON and OFF a couple of times to help prime the pump.

## 3.2. INSTALLATION

Install the welding power supply in structurally sound location such as concrete floor or sturdy base.

**Do not use or install this welding power supply in any of the following locations:**

- A location exposed to wind or rain.
- A steamy or humid location.
- A location subjected to abnormal vibration or shock.
- A location exposed to harmful corrosive gases.
- A location where ambient temperature exceeds 40°C (104°F).
- A location with oil vapor.
- A particularly dusty location.
- A location where the ambient temperature falls below -10°C (14°F).

※ Care should be taken to ensure that the welding arc zone is not directly exposed to wind. Prepare a windshield if necessary.



### CAUTION



- Always turn off the distribution panel switch prior to making electrical connections.
- The forced air-cooling method of the welding power supply intakes air from the rear of the equipment and expels it out the side, a distance of 8 inches (20 cm) or more must be maintained between the equipment and any wall or other obstruction.
- If installing two or more welding power supply units' side by side, separate them by a distance of 1 foot (30 cm) or more.
- When performing continuous welding, do not directly touch the exhaust vent on the side of the welding power supply as hot air is expelled from it. Do not place any combustibles near the exhaust vent.
- To prevent malfunction and damage due to noise received from other welding power supplies, equipment that generate HF or lightning surges, ensure that the equipment is properly grounded utilizing its ground terminal.

## 3.3. WIRING CONNECTION OF INPUT VOLTAGE

### 3.3.1. WIRING THE SUPPLIED INPUT CABLE

 <b>WARNING</b>
☆ Risk of electric shock could result in serious injury or death. ☆ This welding power supply to be installed and serviced by qualified personnel only. ☆ Be sure to turn off the line disconnect switch before performing work. ☆ Use a "Lock-Out/Tag-Out" procedure until installation is complete. ☆ Be sure to connect the earth wire. ☆ Always wire the input cable before wiring the distribution panel.
 <b>CAUTION</b>
☆ Securely fix the power cable in place utilizing the cable clamp located at the back of the device.

The 150PW is equipped with a three-conductor with earth power cable that is connected at the welding power source end for single and three phase electrical input power. The 150PW automatically senses input voltage. No internal wiring required. For Single-Phase operation connect the GREEN, BLACK and WHITE input conductors. Insulate the RED conductor, it is not used for single-phase operation. The welding power source will not operate properly if the BLACK or WHITE wire is exchanged for the RED wire in single-phase operation. **Do not** connect an input (WHITE or BLACK or RED) conductor to the ground terminal.

**Do not** connect the ground (GREEN) conductor to an input line terminal.

- 1) Connect end of ground (GREEN) conductor to a suitable ground. Use a grounding method that complies with all applicable electrical codes.
- 2) Connect the other lines as follows:
  - a) For three-phase input connections: Connect the ends of line 1 (BLACK) and line 2 (WHITE) and line 3 (RED) input conductors to a de-energized line disconnect switch.
  - b) For single-phase input connections: Connect the ends of line 1 (BLACK) and line 2 (WHITE) input conductors to a de-energized line disconnect switch. Insulate the end of line 3 (RED) conductor, as it is not used for single-phase operation.

## Typical Primary connection to Fused Line Disconnect Switch.

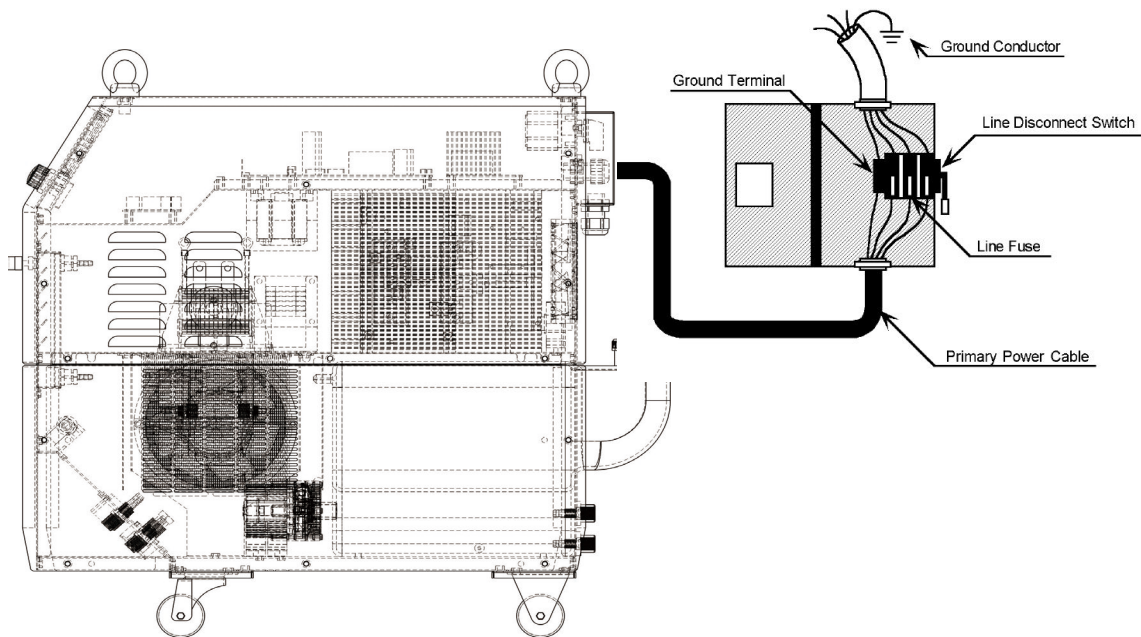

## If replacing the input cable, follow directions below.

- ① Remove the top sheet metal cover.
- ② Remove the Red, Black and White wires from the input switch and the Green wire from the Earth connected with bolt on tray.
- ③ Unscrew the compression clamp holding the input cable then remove the cable.

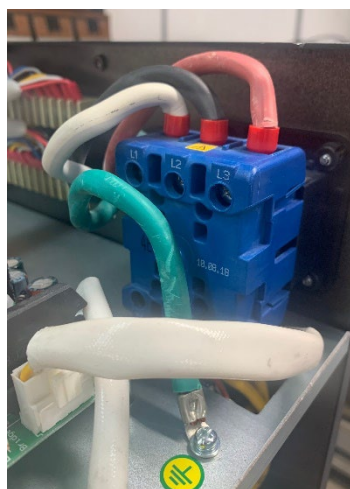

- ④ Install new primary cable through compression clamp and tighten compression clamp securely.
- ⑤ Connect the Red, White and Black wires to Line 1, 2 and 3 of the input switch for three

phase power or the Black and White wires to Line 1 and 2 of the input switch for single phase power and the ground wire to earth bolt on the Tray.

- ⑥ Reinstall the top Metal Cover.



**WARNING**

☆ Be sure to reattach the cover after wiring to the terminal block. Touching any parts that are electrically "live" or "hot" may cause electric shock, burns or death.

### 3.4. WIRING TO THE POWER DISTRIBUTION PANEL

 WARNING	
☆	Risk of electric shock could result in serious injury or death.
☆	This welding power supply to be installed, and serviced by qualified personnel only.
☆	Be sure to turn off the line disconnect switch before performing work.
☆	Use a "Lock-Out/Tag-Out" procedure until installation is complete.
☆	Be sure to connect the earth wire.
☆	Always wire the input cable before wiring the distribution panel.

Connect the red wire, black wire, and white wire of the input cable that is connected to the welding power supply to the no-fuse breaker on the distribution panel or the distribution panel switch (built-in fuse). Always ground the green/yellow wire.

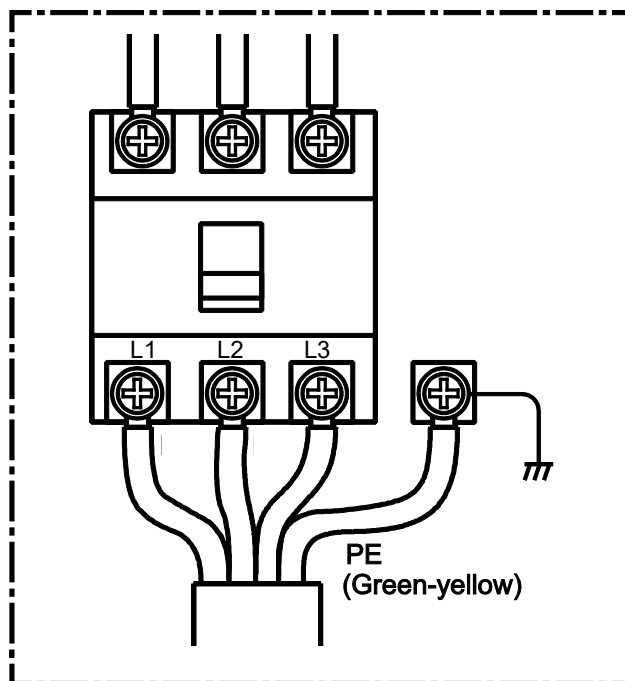

### 3.5. CONNECTING THE ACCESSORIES

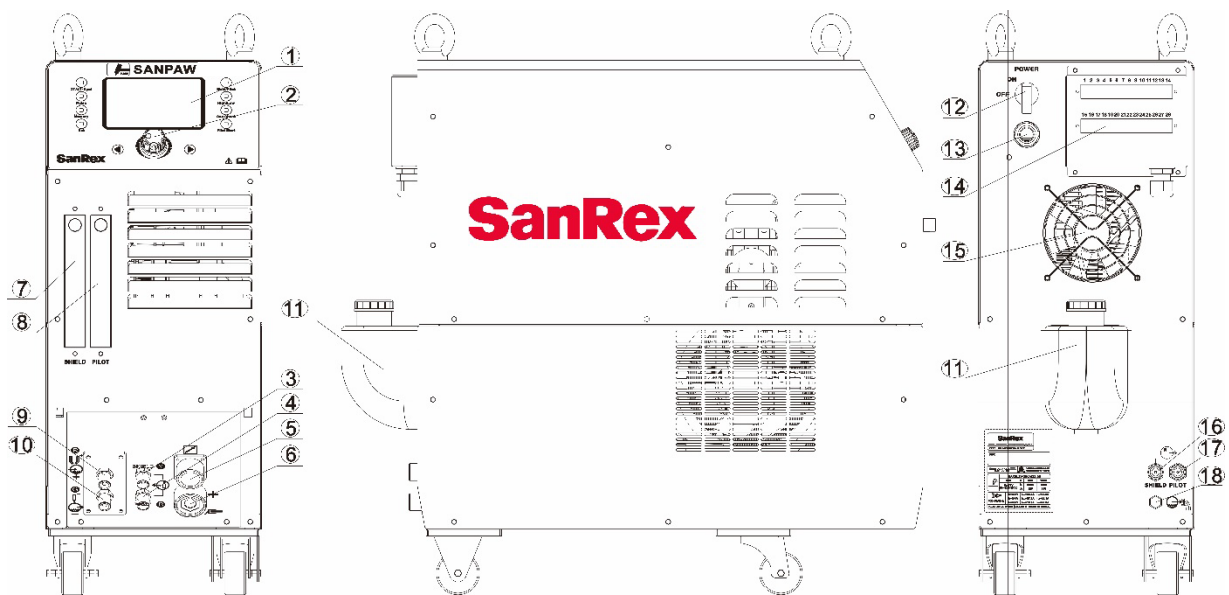

①	5-inch LCD screen	5-inch
②	Master control knob	φ24.3*H20.8 red RAL3020
③	Shield Gas Output (YELLOW Terminal)	9/16-18UNF RH MALE
④	Pilot Gas Output (BLACK Terminal)	9/16-18UNF RH MALE
⑤	Connector for Remote Controller	14-pin, MS3102A20-27S
⑥	Work quick plug	European 50mm Dinse Receptacle
⑦	Shield Gas flow meter	KOFLOC RK1650-15-B-1/8-AR-30SCFH
⑧	Pilot Gas flow meter	KOFLOC RK1650-15-B-1/8-AR-5SCFH
⑨	Coolant Water Return (RED + Terminal) (From Torch)	9/16-18UNF RH MALE
⑩	Coolant Water Supply (GREEN - Terminal) (To Torch)	9/16-18UNF RH MALE
⑪	Coolant tank	3.2 Gal
⑫	power switch	LW26-32F 0-1 3P
⑬	Power input cable	8AWG 4G 3.2M
⑭	Control wiring block	DK-A1.5-757-14P
⑮	cooling fan	DA12025B24UA DC24V 0.65A
⑯	Shield Gas Input	5/8-18 UNF RH FEMALE
⑰	Pilot Gas Input	5/8-18 UNF RH FEMALE
⑱	Coolant Drain	M10X1

PAGE LEFT INTENTIONALLY BLANK

### 3.5.1. WIRING OF REMOTE CONTROLLER OUTLET

Connect the wiring for the torch-side receptacle according to the following table.

Connector type on this welding power supply: Amphenol MS3102A20-27S.

TERMINAL	FUNCTION		DIRECTION	REMARKS
A	Main Start Signal		Input	
B	Main Start Signal (closure between pin A and pin B will energize output)		Input	
C	External Peak (welding) Current Setting Signal	5k ohm (maximum) connection to 5kΩ remote control potentiometer. (+10V, 2mA max)	Output	
D		Zero-ohm (minimum) connection to 5kΩ remote control potentiometer. (GND)	—	
E		Wiper arm connection to 5kΩ remote control potentiometer. (0~10V) (*1) (*2)	Input	
F	Scaled Output Main Current Signal: $I_{fb} = 100A/1V$		Output	Max 5mA
G	Chassis Ground		—	
H	Scaled Output Main Voltage Signal: $V_{fb} = 10V/1V$		Output	Max 5mA
I	Control Circuit Common (F & H)		Output	
J	NC		—	
K	Pilot Start Signal		Input	
L	Pilot Start Signal (closure between pin K and pin L will energize output)		Input	
M	OK to Move Current Detect Signal		Output	DC 0.1A / 30V or less
N	OK to Move Current Detect Signal		Output	

(\*1) Enabling the output current setting in Setup to ON when utilizing a Hand Pendant, Foot control or an external current command.

 **CAUTION**

☆ Wire the signal lines of terminal symbol C, D, E, F, H, I separately from power lines such as input cable and output cable (base material cable, torch cable).

### 3.5.2. CONNECTION TO EXTERNAL OUTPUT SIGNAL TERMINAL BLOCK

The connection to external input output terminal block, please follow the list below.

For details of functions, see section "5.1. FUNCTION FOR AUTOMATION".

Terminal block specification: Screw Terminal (M3); 14position × 2. Spade connector Size M3 – 0.22".

TERMINAL	FUNCTION		INPUT OUTPUT	REMARKS
1	Main Start Signal		Input	
2	Main Start Signal (*3) (closure between terminal1 and 2 will energize output)		Input	
3	Pilot Start Signal		Input	
4	Pilot Start Signal (*3) (closure between terminal3 and 4 will energize output)		Input	
5	Gas Check Signal		Input	
6	Gas Check Signal (*3) (closure between terminal3 and 4 will energize output)		Input	
7	Emergency Stop Signal		Input	
8	Emergency Stop Signal (*3) (welding output is disabled when the contact is "Open" operating mode is enabled when the contact is "Closed")		Input	
9	User Saved File Selection Signal	bit0	Input	
10		bit1	Input	
11		bit2	Input	
12		bit3	Input	
13	User Saved File Selection Signal (*3) (Selected closure between terminals9, 10, 11, 12 to terminal 13 will retrieve a previously saved file) * Refer to section 5.1. FUNCTION FOR AUTOMATION		—	
14	NC		—	—
15	OK to Move Current Detect Signal		Output	DC 0.1A / 30V or less
16	OK to Move Current Detect Signal		Output	
17	Pilot Current Detect Signal		Output	DC 0.1A / 30V or less
18	Pilot Current Detect Signal		Output	
19	Error Signal		Output	DC 0.1A / 30V or less
20			Output	
21	Pulse Synchronization Signal		Output	Max 30VDC Max 50mA
22	* Refer to section 5.1. FUNCTION FOR AUTOMATION			

23	External Peak	5k ohm (maximum) connection to 5kΩ remote control potentiometer. (+10V, 2mA max)	Output	
24	(welding) Current	Wiper arm connection to 5kΩ remote control potentiometer. (0~10V) (*1) (*2)	Input	
25	Setting Signal	Zero-ohm (minimum) connection to 5kΩ remote control potentiometer. (GND) (*4)	—	
26	Scaled Output Main Voltage Signal: $V_{fb} = 10V/1V$		Output	Max 5mA
27	Scaled Output Main Current Signal $I_{fb} = 100A/1V$		Output	Max 5mA
28	Control Circuit Common (for pins 26&27) (*4)		Output	

- (\*1) Enabling the output current setting in Setup to ON when utilizing a Hand Pendant, Foot control or an external current command.
- (\*2) Terminal 2,4,6,8,13 is common internally to the welding power supply.
- (\*3) Terminal 25, 28 are common internally to the welding power supply.

**NOTE**



Common signals of the External Input / Output Signal Terminal Block and the Remote Controller Outlet are connected to each other inside the welding power supply. (As shown below)

SIGNAL NAME		EXTERNAL INPUT/OUTPUT TERMINAL BLOCK		REMOTE 14 Pin RECEPTACLE
Main Start Signal		1	↔	A
Main Start Signal (common)		2	↔	B
Pilot Start Signal		3	↔	K
Pilot Start Signal(common)		4	↔	L
OK to Move Current Detect Signal		15	↔	M
OK to Move Current Detect Signal		16	↔	N
External Peak	+10V Output	23	↔	C
(welding) Current	0-10V Input	24	↔	E
Setting Signal	GND	25	↔	D
Scaled Output Main Voltage Signal		26	↔	H
Scaled Output Main Current Signal		27	↔	F
Control Circuit Common (for pins 26&27, H & F)		28	↔	I

**CAUTION**

☆ Wire the signal lines of terminal numbers 23 to 28 separately from power lines such as input cable and output cable (base material cable, torch cable).

### 3.5.3. OUTPUT CABLE, GAS, COOLING WATER UNIT CONNECTIONS

(\*1) When using a foot control or remote Pendant, connect to the 14-pin connector on the front panel. (See section "3.5.1. WIRING OF REMOTE CONTROLLER OUTLET")

At the same time, enable the 14-pin connector by turning ON the REMOTE Mode in Setup. (See section"4.1. USER INTERFACE OVERVIEW AND OPERATION")

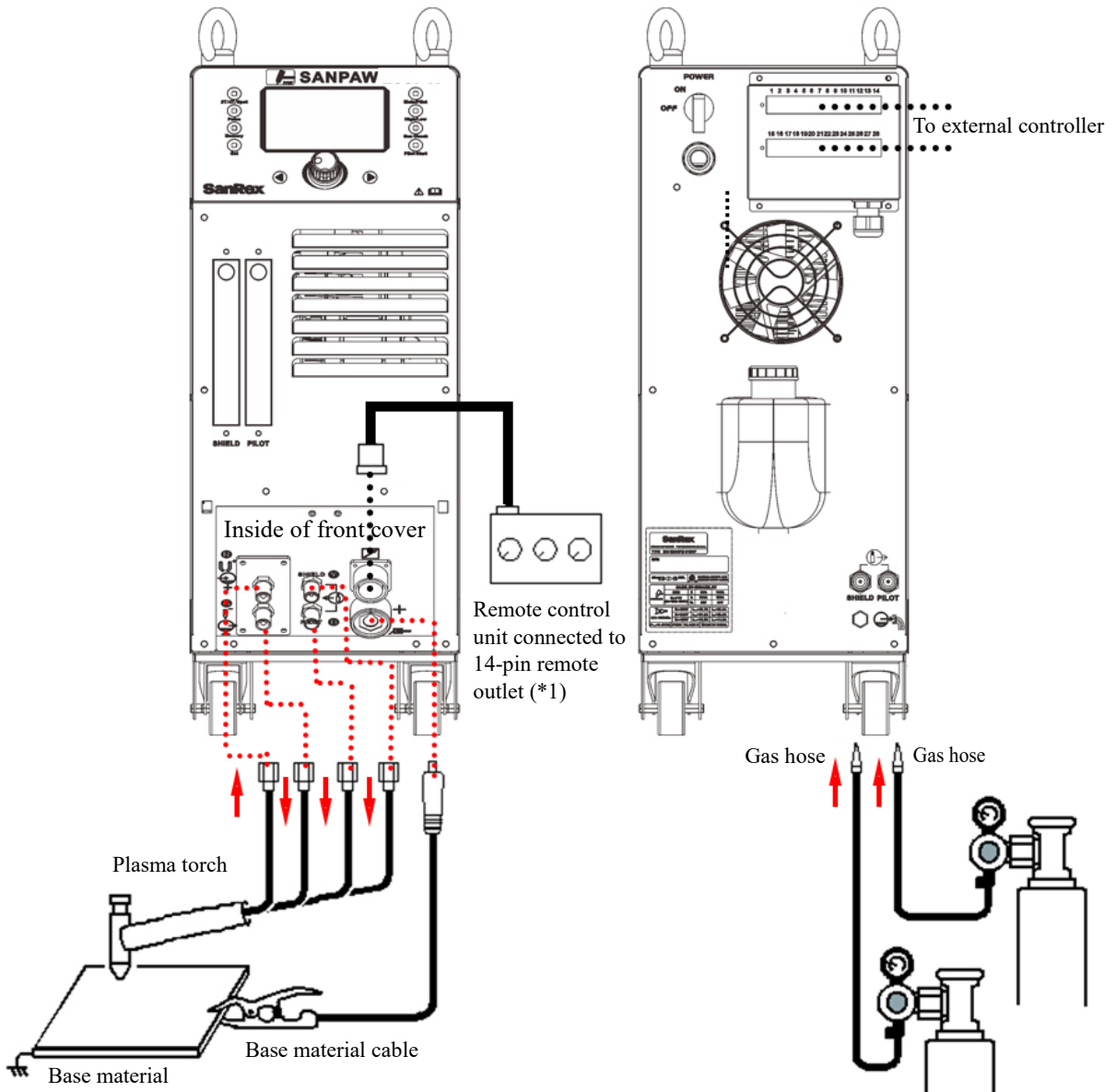

- **GAS CONNECTION:**

Prepare two argon gas supplies or one Argon and one Argon/Hydrogen gas supply. One gas supply dedicated for pilot gas and the second dedicated for the shield gas. Attach a regulator (without flow meters) to each of the argon gas supplies and connect the regulator output to the gas inlets on the welding power supply with gas hoses. Ensure that the gas pressure is 35~40 psi during use. See Torch manual for proper gas used on material welded. Note: Gas connection Wrench if needed use Part Number MS1016.

**CAUTION**



Various plasma welding torches can be utilized with the 150PW. Use the Sanrex P75, P15 or P22 Plasma Welding Torches or equivalent. It is the responsibility of the user to determine the proper torch.

- **TORCH CONNECTION:**

- Connect the Coolant Water Return metal fitting (RED + output metal fitting) of the plasma welding torch to the Coolant Water Return (RED + terminal) of the welding power supply (right top of the front panel).
- Connect the Coolant Water Supply metal fitting (GREEN - output fitting) of the torch for plasma welding to the Coolant Water Supply (GREEN - terminal) of the welding power supply (right bottom of the front panel).
- Connect the welding object (base material) and the output base material terminal (+) (left side of the front panel).
- Connect the pilot gas metal fitting of the plasma welding torch to the pilot gas output, BLACK Terminal, of the welding power supply (center bottom of the front panel).
- Connect the shield gas fitting of the plasma welding torch to the shielding gas output, YELLOW terminal, of the welding power supply (center top of the front panel).



**WARNING**

- ☆ Turn off the power switch before wiring the output side.
- ☆ Securely tighten all connectors so there are no loose connections and ensure there are no water or gas leaks.

PAGE LEFT INTENTIONALLY BLANK

## 4. OPERATION PROCEDURES

### 4.1. USER INTERFACE OVERVIEW AND OPERATION

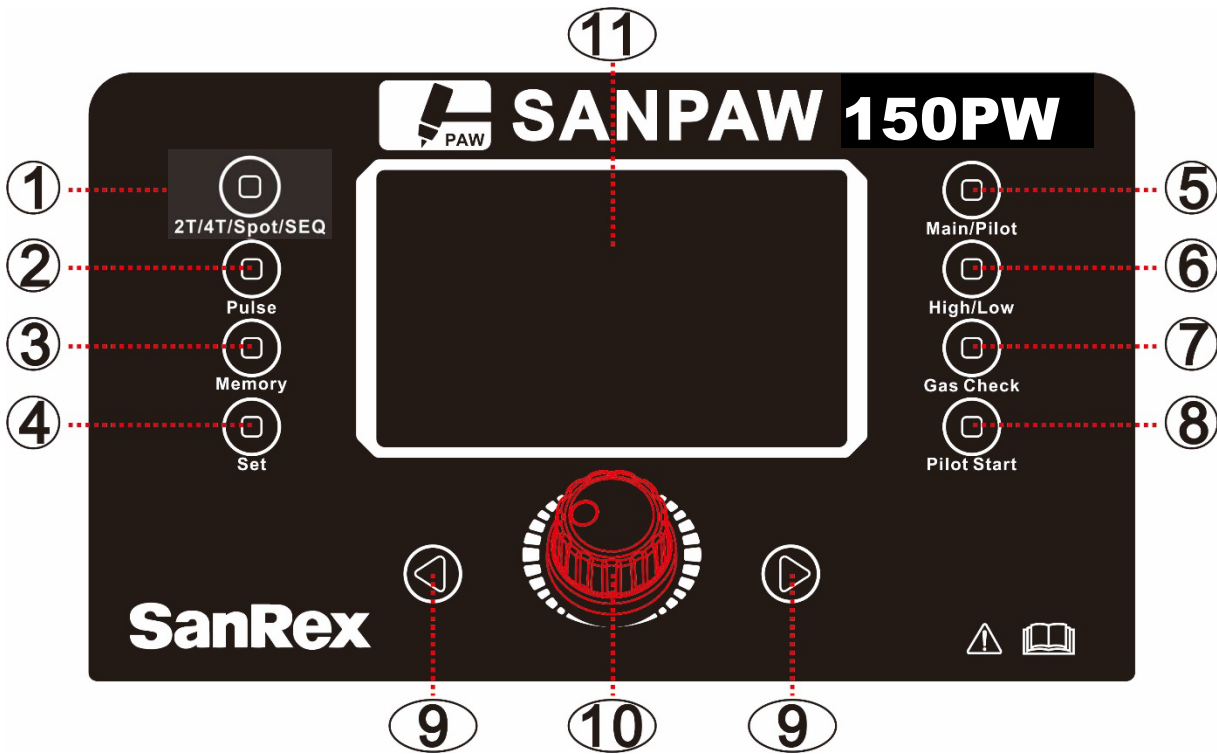

[1] **2T/4T/Spot/SEQ**

Output Contactor Mode Button. Pressing this button changes the welding sequence (2T, 4T, SPOT, SEQ).

The sequence changes in order:

"2T" → "4T" → "SPOT" → "2T" → "SEQ"

With each press of the button. It becomes the repeat operation at "4T" by turning internal parameter P21 setting on. (See section "4.3. WELDING PROCESSES")

[2] **Pulse**

Pressing this button changes the pulse setting (PULSE ON, PULSE OFF).

[3] **Memory**

This button is used to save the state of the configured welding process, welding sequence, and parameters to the 150PW or Flash Drive. (See section "5.2 SAVE/LOAD FUNCTIONS")

[4] **SET**

For initial Setup of remote Amperage, Pre Purge Gas and I/O parameters.

SET button is also used to clear an error code and return to the standby state when an abnormal condition is detected. (See section "8.1. ERROR CODE LIST "WELDING PROCESSES")

[5] **Main/Pilot**

Pressing this button changes the parameter selection of MAIN current display or PILOT current display. The parameter changes in the following order:

"MAIN" → "PILOT" → "MAIN"

With each press of the button.

The actual sequence of parameter selection will change depending on the configuration.

[6] **High And Low**

Pressing this button changes the current range. In high current mode, the current output range is 5-200 Amps. In low current mode, the main current output range is 0.5-20.0 Amps.

[7] **Gas Check**

Pressing this button will energize the gas solenoids and start the shield gas and pilot gas flow.

Gas solenoids do not automatically turn off. Turn off gas solenoids by pressing the Gas Check button.

Welding can be performed with Gas Check ON.

[8] **PILOT Start**

Pressing this button will enable/disable the operation of the pilot output. Same operation as pilot start signal.

[9] **Parameter Arrow Buttons**

Pressing either of these two buttons changes the selection of welding parameters.

The parameters that can be selected differ according to the welding process and waveform mode setting. (See section "4.3. WELDING PROCESSES")

[10] **Encoder**

Turn to change the value of the parameters.

In set mode push to select parameter.

## 4.2. WELDING PARAMETER DESCRIPTIONS

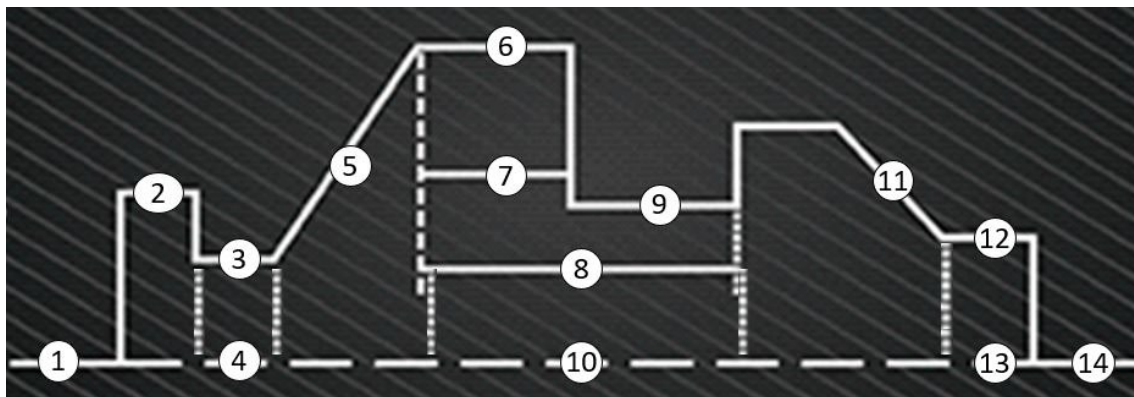

PANEL DISPLAY NAME		MAIN	PILOT
①	PREFLOW	Pre-Flow Time of Shield Gas	—
②	HOT START	Main Hot Current	—
③	INITIAL CURRENT	Initial Welding Current	—
④	INITIAL CURRENT TIME	Time of Initial Current	—
⑤	UP SLOPE TIME	Time of Up Slope	—
⑥	PEAK CURRENT (WELD/PULSE/PILOT)	Peak Current With Pulse / Welding Current without Pulse	—
⑦	PULSE WIDTH	Ration of Pulse Peak Current Time (%)	—
⑧	FREQ.	Pulse Frequency Hz.	—
⑨	PULSE BASE CURRENT	Base Current Ratio Base current equals $\text{⑤[A]} \times \text{⑧}[\%]$	—
⑩	PEAK CURRENT TIME	Time at Peak Current	
⑪	DOWN SLOPE TIME	Time of Down Slope	—
⑫	CRATER. CURRENT	Crater Current	—
⑬	CRATER CURRENT TIME	Time at Crater Current	

PANEL DISPLAY NAME		MAIN	PILOT
⑭	POST FLOW	Post-Flow Time of Shield Gas	—
	SPOT TIME	Spot Current Time	—

The configurable range and initial value of each parameter is shown in the following table.

	PARAMETER NAME		MIN.	MAX.	INITIAL VALUE	UNIT
MAIN	PREFLOW	Tpre	0.0	25.0	0.3	sec
	HOT START CUR.	Ih	0	70	0	A
	INITIAL CUR.	Ii	0.5/5	20/200	50	A
	INITIAL CURRENT TIME	Tict	0	30		sec
	UP SLOPE	Tup	0.0	25.0	0.1	sec
	PEAK CUR.	Ip /Iw	0.5/5	20/200	120	A
	PEAK CURRENT TIME	Tpct	0	600		sec
	BASE CUR. (*1)	Ib	1	100	50	%
	WIDTH	d2	5	95	50	%
	FREQ.(*2)	f2	0.5	500	250	Hz
	DOWN SLOPE	Tdw	0.0	25.0	0.6	sec
	CRATER CUR.	Ic	0.5/5	20/200	30	A
	CRATER CURRENT TIME	Tect	0	30		sec
	POST FLOW	Tpos	0.0	60.0	2.0	sec
	SPOT TIME	Tsp	0.1	25.0	2.0	sec
PILOT	PILOT CUR.	Ipl	1	20	10	A
INTERNAL PARAMETER	Pilot Gas Pre-Flow Time		0.0	5.0	0.0	sec

(\*1) Base Current is set by ration (%) to peak (welding) current setting value. When Base Current calculation value is lower than minimum current, it fixes to minimum current.

(\*2) Pulse frequency resolution depends on settings of frequency shown below.

SETTING RANGE	UNIT
0.5 to 10	0.1Hz
10 to 500	1Hz

## 4.3. WELDING PROCESSES

### 4.3.1. PILOT OUTPUT

- Operation elements

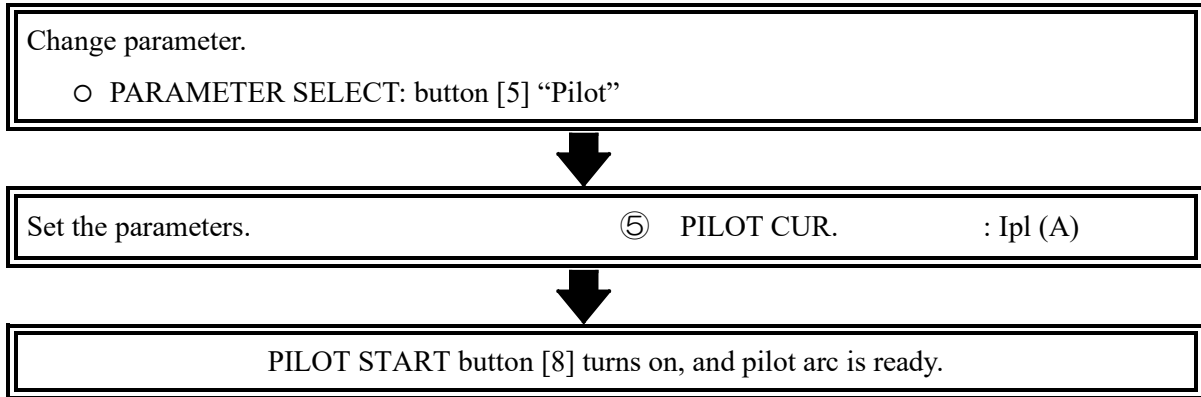

- Operation sequence

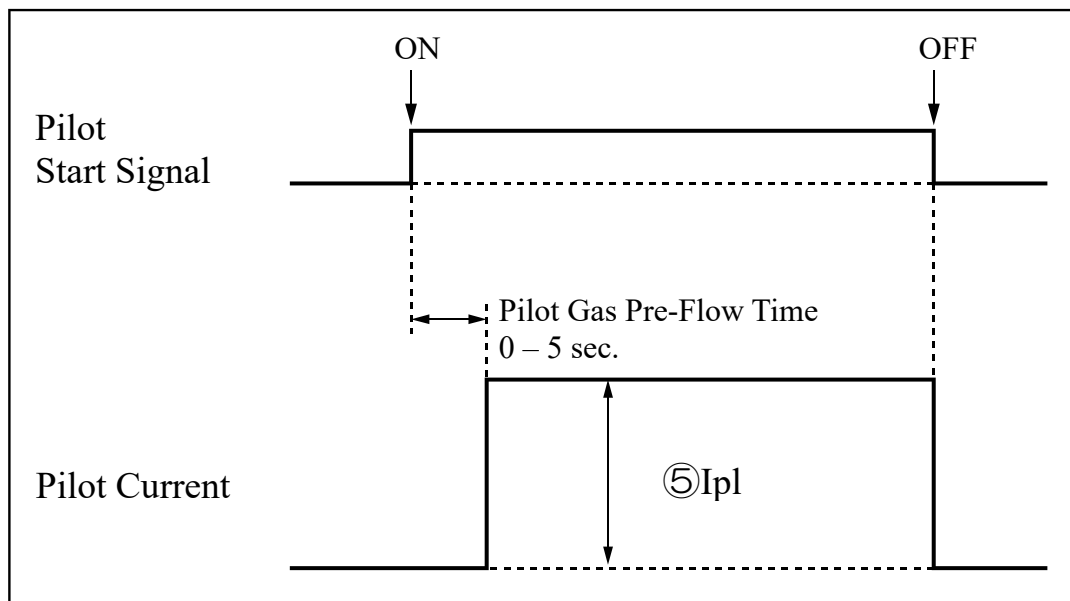

## 4.3.2. MAIN OUTPUT

### 4.3.2.1. 2T MODE (WITH SLOPE)

- Operation elements

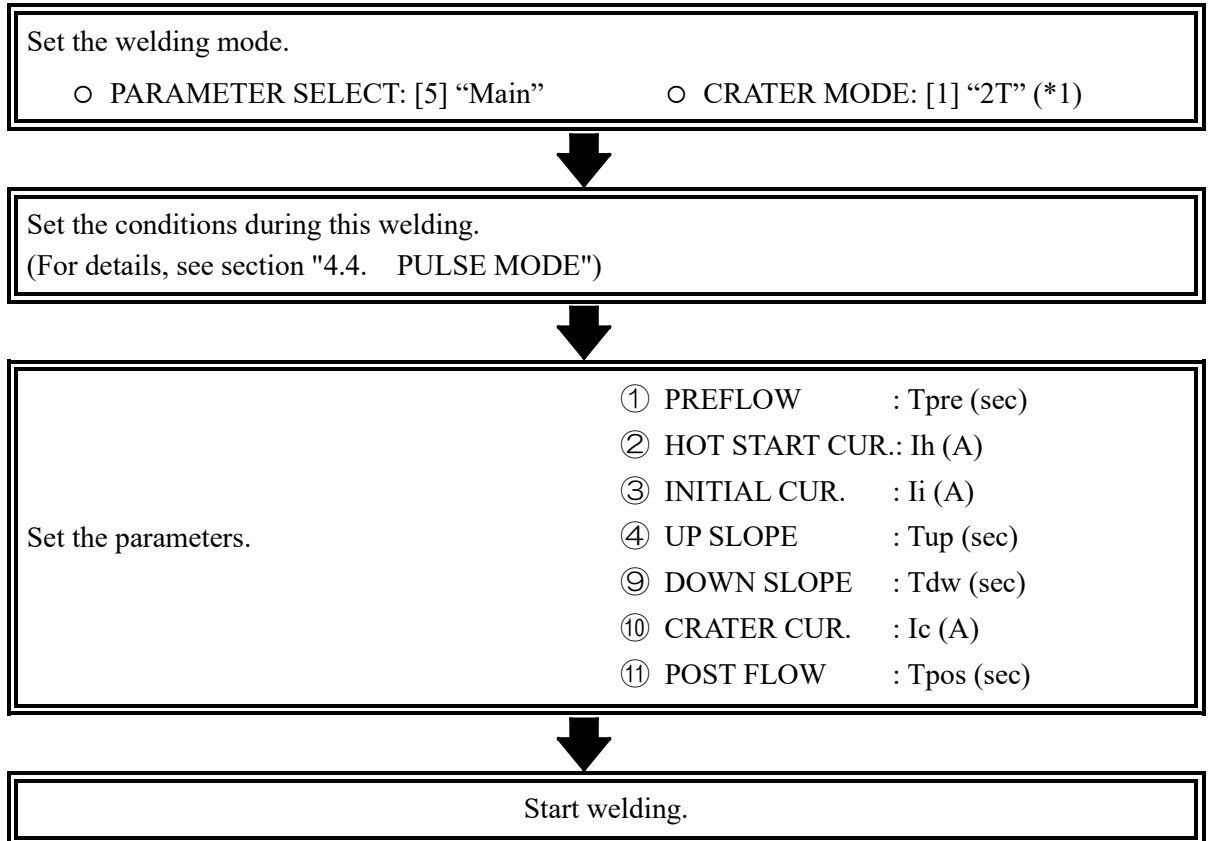

- Operation sequence

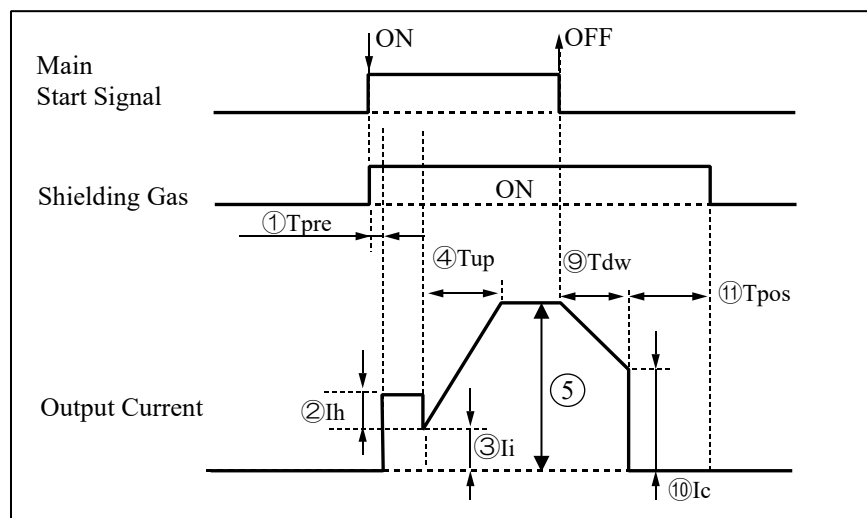

(\*1) In 2T mode, SLOPE can be enabled or disabled by setting 2T SLOPE Function.

### 4.3.2.2. 4T MODE (WHEN P20: 4T MODE SETTING IS ON)

- Operation elements

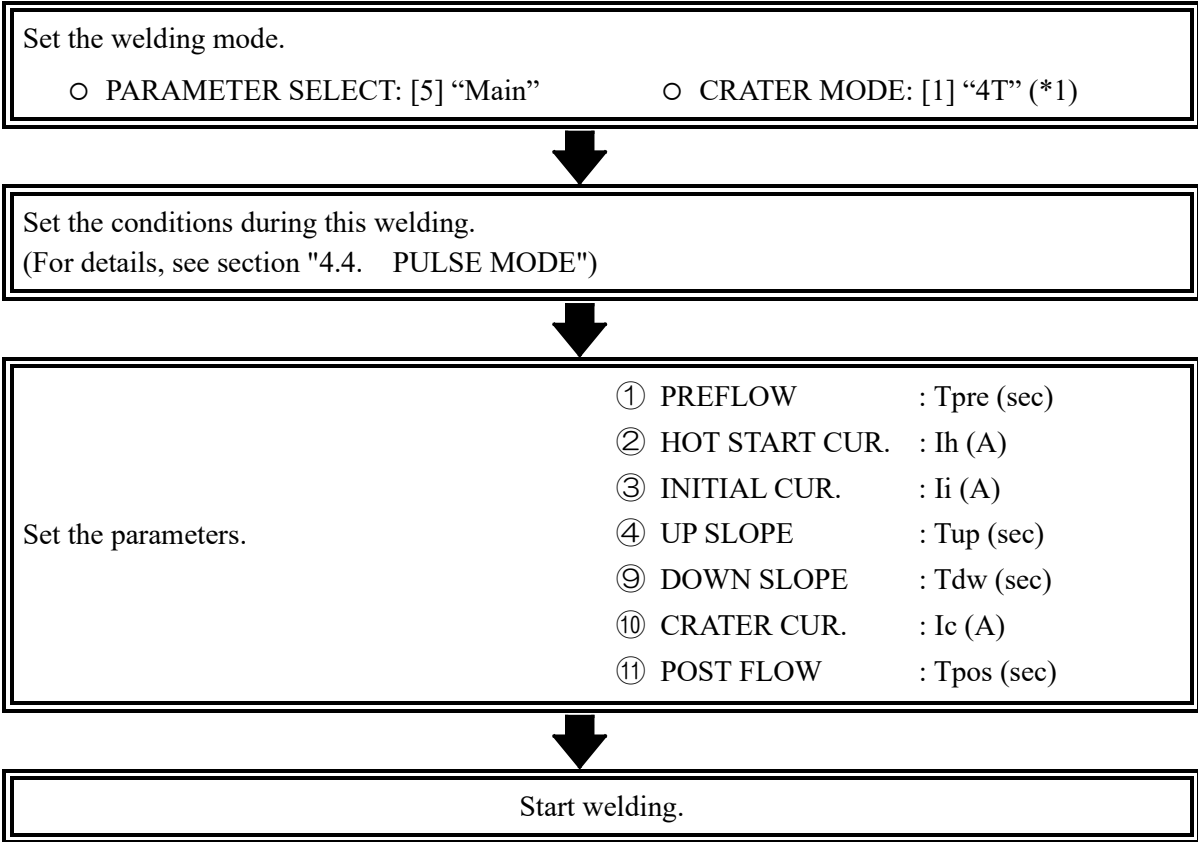

- Operation sequence

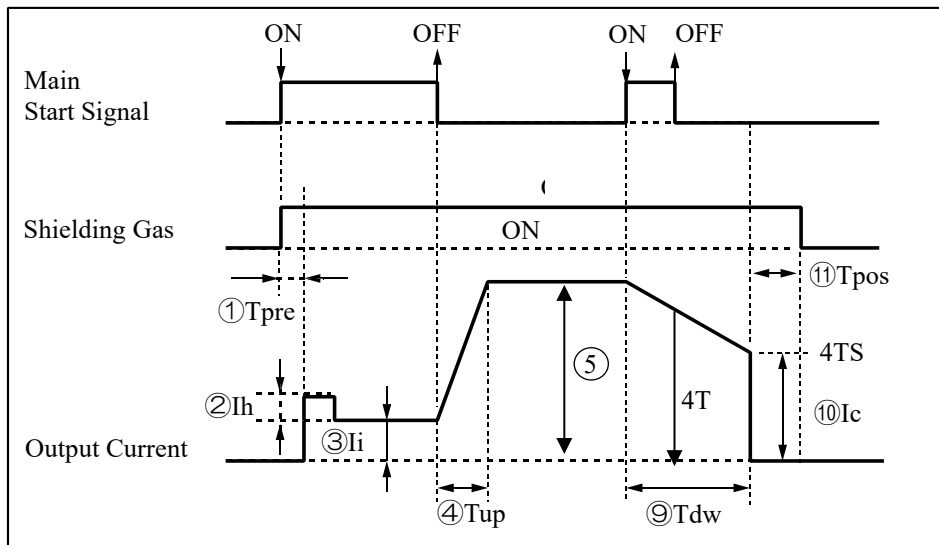

(\*1) In 4T mode, the operation when welding ends can be set to be synchronized or not synchronized with the main start signal by setting Pulse Signal Output.

### 4.3.2.3. REPEAT MODE

- Operation elements

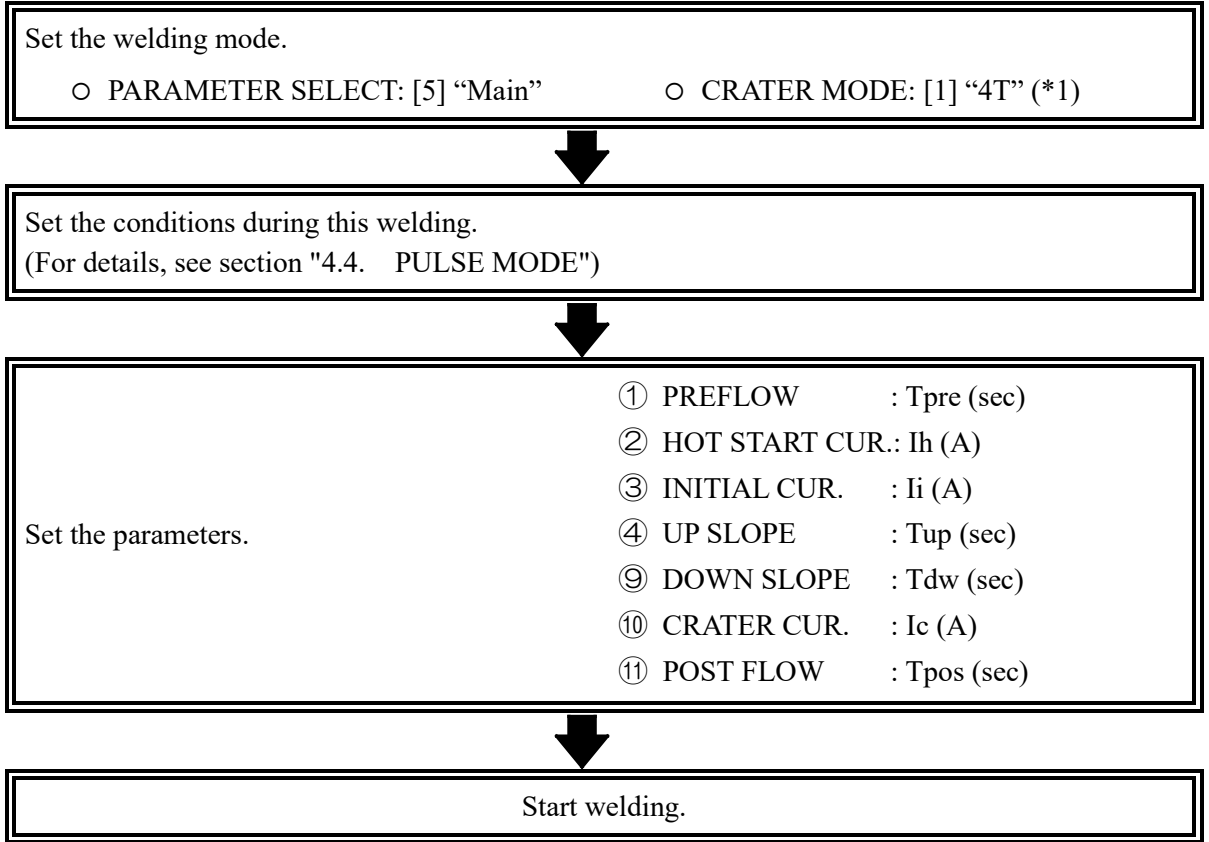

- Operation sequence

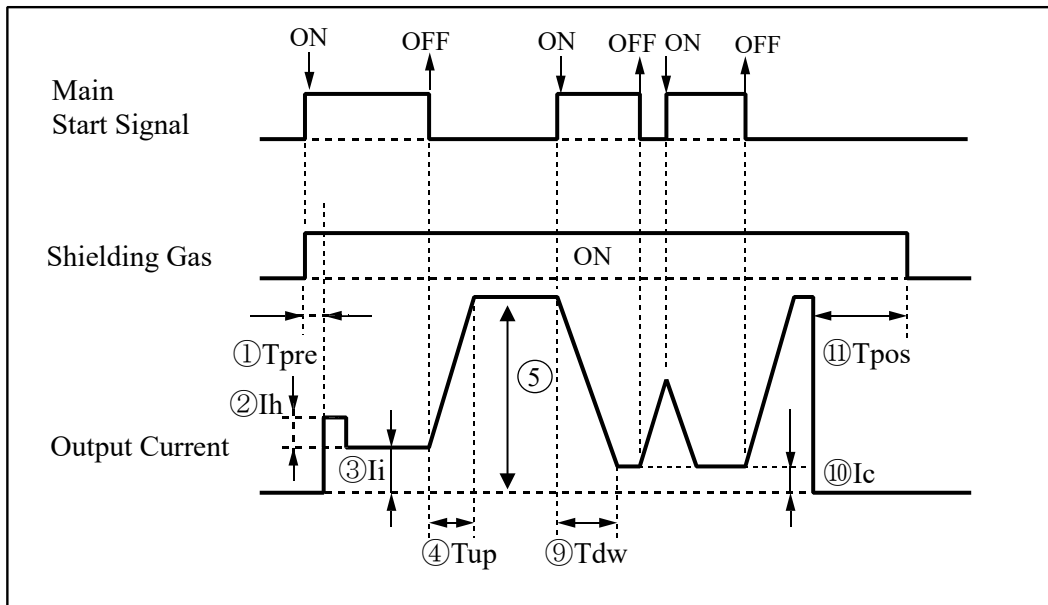

(\*1) The REPEAT operation is enabled by turn ON the setting SELECT 4T/4TS/REPEAT.

#### 4.3.2.4. SPOT MODE

- Operation elements

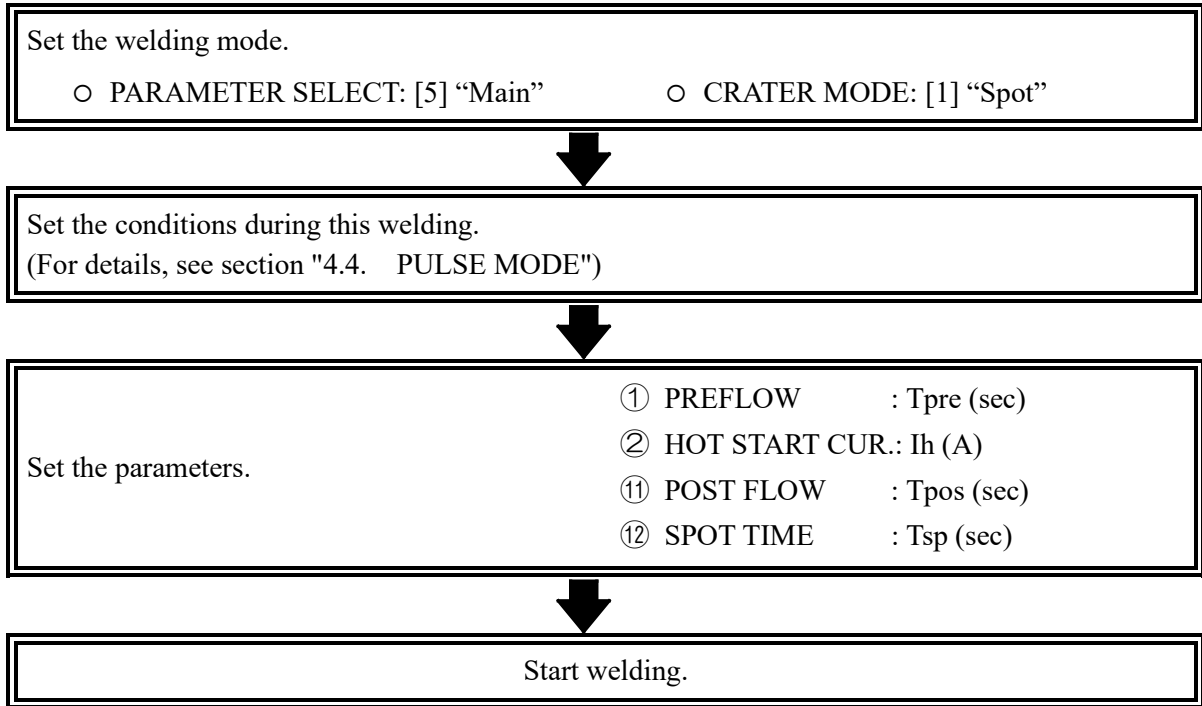

- Operation sequence

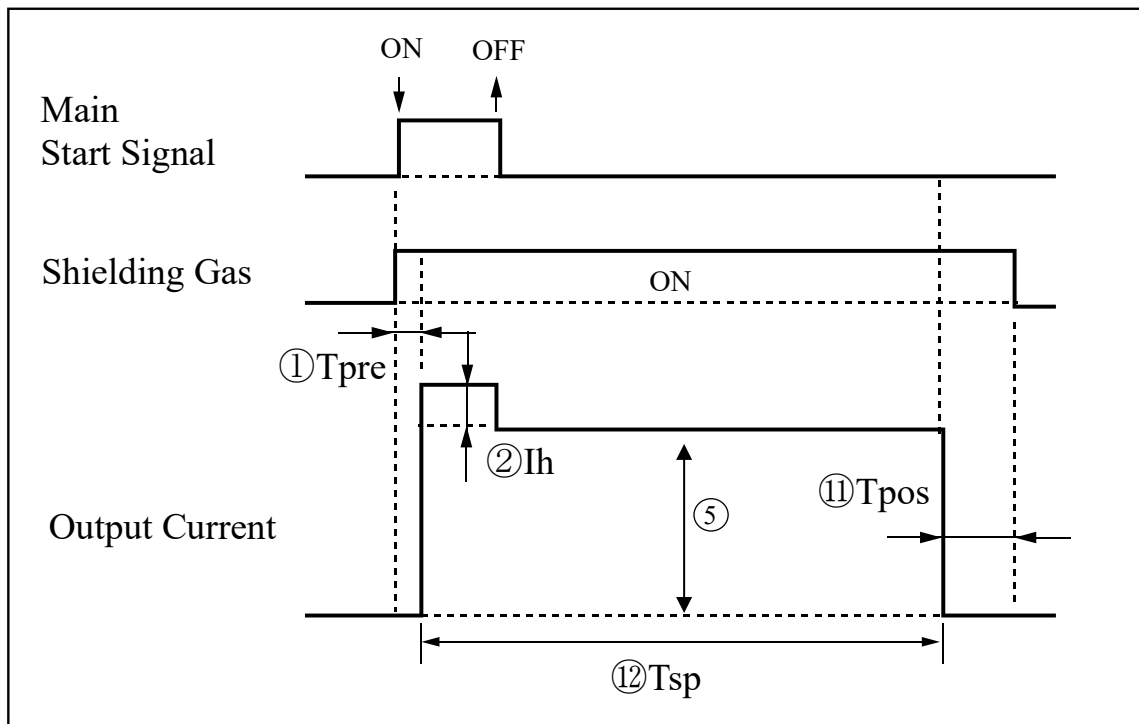

## 4.4. PULSE MODE

### 4.4.1. PULSE MODE

- Operation elements

Set the pulse mode.  
○ PULSE: [2] "ON"



Set the parameters.

- ⑤ PEAK CUR. :  $I_p$  (A)
- ⑥ WIDTH :  $d_2$  (%)
- ⑦ FREQ. :  $f_2$  (Hz)
- ⑧ BASE CUR. :  $I_b$  (A)

- Waveform

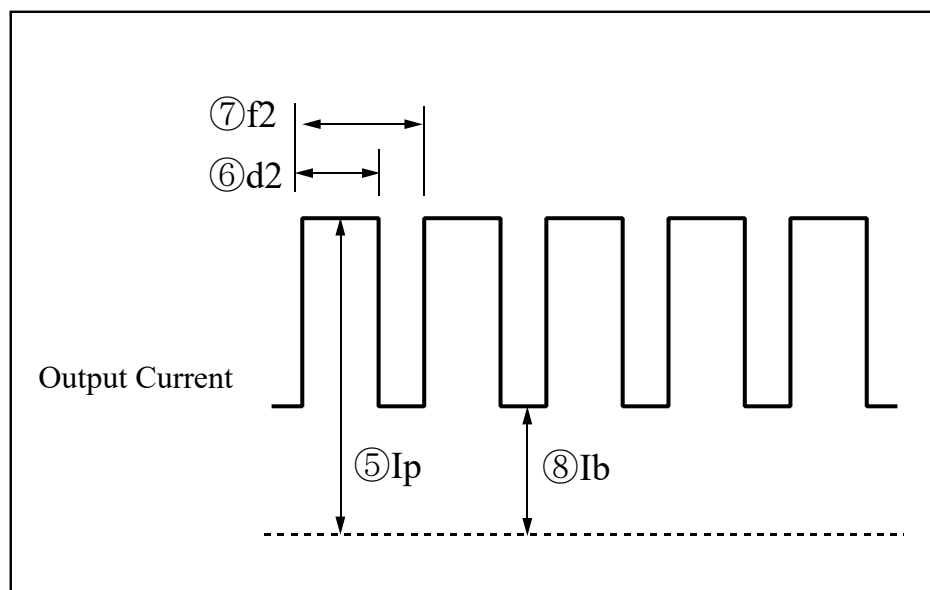

# 5. FUNCTIONS

## 5.1. FUNCTION FOR AUTOMATION

The external input and output signals shown below can be used for automation by connecting an external controller to the External Input Output Signal Terminal Block.

1. Main Start Signal: Terminal Numbers: 1, 2  
An externally received contactor closure condition will turn the main output ON.
2. Pilot Start Signal: Terminal Numbers: 3, 4  
An externally received contactor closure condition will turn the pilot output ON.  
Note: This is the same function as utilizing the “PILOT ON/OFF” button on the front panel.
3. Gas Check Signal: Terminal Numbers: 5, 6  
An externally received contactor closure condition will turn the shield gas and pilot gas ON.  
Note: The shield gas and pilot gas are both ON when the gas check signal is ON.
4. Emergency Stop Signal: Terminal Numbers: 7, 8  
An externally received contactor open condition initiates an emergency stop (Error code E09).  
Output current will turn OFF.
5. User Saved File Selection Signal: Terminal Numbers: 9, 10, 11, 12, 13  
Externally received contact closures can retrieve previously saved user welding parameters. Defined by the input status of the terminal block and the status of internal parameter external call of user saved data. Only previously saved user file numbers 1~9 are retrievable using the External Input/Output Signal Terminal Block. Previously saved user file numbers 1~9 are retrievable thru the front operator panel. Saved data is not retrieved when terminal 9~12 are all OFF, contacts open, and the current parameters are retained. Retrieving data is only possible during stand-by and welding.  
Terminal 9: bit 0  
Terminal 10: bit 1  
Terminal 11: bit 2  
Terminal 12: bit 3  
Terminal 13: common  
Note: The external retrieving function of user saved data is only available when internal parameter external call of user saved data is “ON”.

INTERNAL PARAMETER P40 SETTING	TERMINAL NUMBER				LOAD DATA NO.
	12 (bit3)	11 (bit2)	10 (bit1)	9 (bit0)	
OFF	-	-	-	-	Invalid terminal block input.
ON	OFF	OFF	OFF	OFF	Saved data is not retrieved
	OFF	OFF	OFF	ON	1
	OFF	OFF	ON	OFF	2
	OFF	OFF	ON	ON	3
	OFF	ON	OFF	OFF	4
	OFF	ON	OFF	ON	5
	OFF	ON	ON	OFF	6
	OFF	ON	ON	ON	7
	ON	OFF	OFF	OFF	8
	ON	OFF	OFF	ON	9

Note: ON = contact closure to terminal 13, OFF = contact open.

6. OK to Move Current Detect Signal: Terminal Numbers: 15, 16

An internal contactor closure output condition indicates that main current flows.

Note: The contact output logic can be inverted by OK-TO-Move Current Detect Output.

(An internal contactor open output condition indicates the main current flows.)

7. Pilot Current Detect Signal: Terminal Numbers: 17, 18

An internal contactor closure output condition indicates that pilot current flows.

Note: The contact output logic can be inverted by PILOT-CUR Detect Signal Output.

(An internal contactor open output condition indicates the pilot current flows.)

8. Error Signal: Terminal Numbers: 19, 20

An internal contactor closure output condition indicates an abnormal condition.

An error code is displayed on the front panel digital display.

Note: The contact output logic can be inverted by turning internal parameter error signal output ON.

(An internal contactor open output condition indicates an abnormal condition.)

9. Pulse Synchronization Signal: Terminal Numbers: 21, 22

An internal open collector signal turns ON during peak current flow.

The pulse synchronization signal is output only when the frequency is less than 20Hz.

Terminal 21, open collector (50mA max)

Terminal 22, return.

Note: The open collector signal logic can be inverted by turning internal parameter Pulse Signal Output ON.

(An internal open collector signal turns ON during base current flow.)

10. External Peak (welding) Current Setting Signal: Terminal Numbers: 23, 24, 25

The peak current (welding current) can be set within the range of 5-200A remotely by utilizing a 0-10VDC analog voltage.

Terminal 23, +10VDC output.

Terminal 24, 0~10VDC analog signal input.

Terminal 25, return.

This remote function is available when the Change REMOTE Mode button is ON.

Change REMOTE Mode button is set to ON...

External current setting value: ENABLED, Panel current setting value: DISABLED.

Change REMOTE Mode button is set to OFF...

External current setting value: DISABLED, Panel current setting value: ENABLED.

11. Scaled Output Main Voltage Signal: Terminal Numbers: 26, 28

Monitor voltage is output in the ratio of 1V to main output voltage of 10V.

Terminal 26: scaled output voltage signal (5mA max)

Terminal 28: return

12. Scaled Output Main Current Signal: Terminal Number : 27, 28

Monitor voltage is output in the ratio of 1V to main output current of 100A.

Terminal 27: scaled output current signal (5mA max)

Terminal 28: return



☆ Wire the signal lines of terminal numbers 23 to 28 separately from power lines such as input cable and output cable (base material cable, torch cable).

## 5.2. SAVE/LOAD FUNCTIONS

You can save and load configured welding conditions to the 150PW or a Flash Drive through the USB Port (welding process, welding sequence, parameters, REMOTE setting). Up to 9 sets of welding conditions can be saved to the 150PW. Located on Front Panel. Memory Button.

### 5.2.1. MACH MEM Function

- a) Pressing the Memory button takes you to the Memory Screen seen below. Rotate the Encoder to highlight USB MEM (Access to USB Flash Drive) or MACH MEM (Saves and Loads configured welding conditions to 150PW).

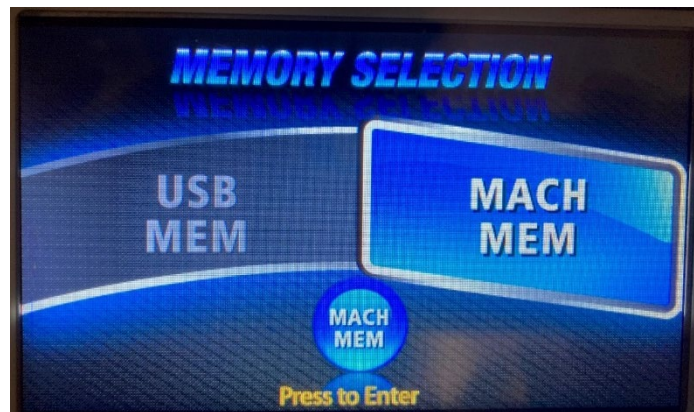

- b) With MACH MEM selected press the Encoder button, this takes you to the Memory Screen seen below. Rotate Encoder to highlight SAVE or LOAD. Push encoder button to continue.



- c) Push encoder button opens the SAVE/LOAD selection screen. SAVE Screen shown below.



- d) To SAVE rotate Encoder knob to desired Memory location (M1 – M9). Push Encoder knob and confirm SAVE Weld Conditions to Memory YES/NO.
- e) To LOAD rotate Encoder knob to desired Memory Location (M1 – M9). Push Encoder knob and confirm LOAD of Weld Conditions for use YES/NO.
- f) Push Memory button to exit.

Note: Last Weld is weld conditions ready to save for the most recent weld Conditions.

## 5.2.2. USB MEM Function

- a) Insert USB Flash drive. Minimum of 4MB of Flash drive required.

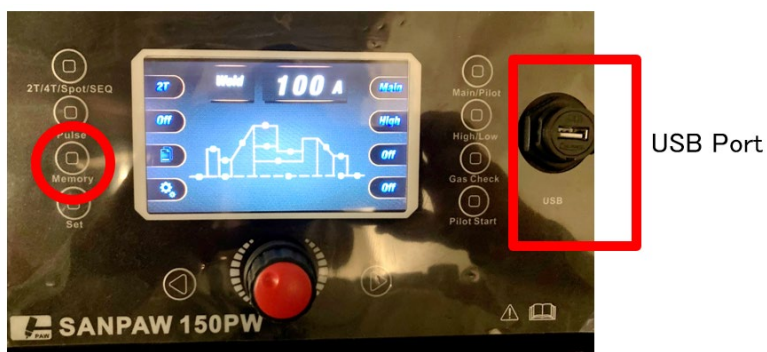

- b) Press Memory button and rotate the Encoder to highlight USB MEM (Access to USB Flash Drive).  
c) Press the Encoder Button.  
d) Select SAVE to save all settings data on 150PW to USB Flash Drive or LOAD to transfer all settings data from USB Flash Drive to 150PW. Note: Data transfer will take approximately 30 seconds.  
e) Press the Encoder Button to start USB operation.

## 6. INTERNAL PARAMETER SETTING

### 6.1. INTERNAL PARAMETER DESCRIPTION

The settings of the internal parameters can be changed for the following functions. The settings are changed by pressing the SET Button. Use the Left and Right Arrow buttons to select parameter. Use encoder Knob to change parameter. Function displayed on the digital panel meter.

FUNCTION	CONFIGURABLE RANGE	UNIT	DEFAULT SETTING
Peak Current Maximum Setting	OFF/ON	-	OFF
2T Slope Function	OFF/ON	-	OFF
Select 4T/4TS/REPEAT/SEQ		-	4T
Start Signal, Sequence Mode	Latching/Momentary	-	
Pulse Signal Output	OFF/ON	-	OFF
OK to Move Current Detect Output	OFF/ON	-	OFF
Pilot Current Detect Signal Output	OFF/ON	-	OFF
Pilot Gas Pre-Flow	0 – 5 sec.	-	0 sec
External Call of User Saved Data	OFF/ON	-	OFF
Error Signal Output	OFF/ON	-	OFF

#### 6.1.1. PEAK CURRENT MAXIMUM SETTING

Set the operation of peak current when in REMOTE Mode (when the Change REMOTE Mode button is ON)  
The peak current value to the remote controller outlet or peak of external input output signal (welding) current order input (0-10V) is

- ON : It changes by the range of minimum current (0.5/5A) to Maximum current (20/200A).
- OFF : It changes by the range of minimum current (0.5/5A) to panel setting current value.

## 6.1.2. 2T SLOPE FUNCTION

This function controls the slope in 2T mode. When the function is enabled (ON), the UP SLOPE, DOWN SLOPE, INITIAL CUR, and CRATER CUR settings are available for modification. The output current waveform when this function is enabled and when it is disabled (OFF) is shown in the following figures.

### 2T SLOPE FUNCTION ON

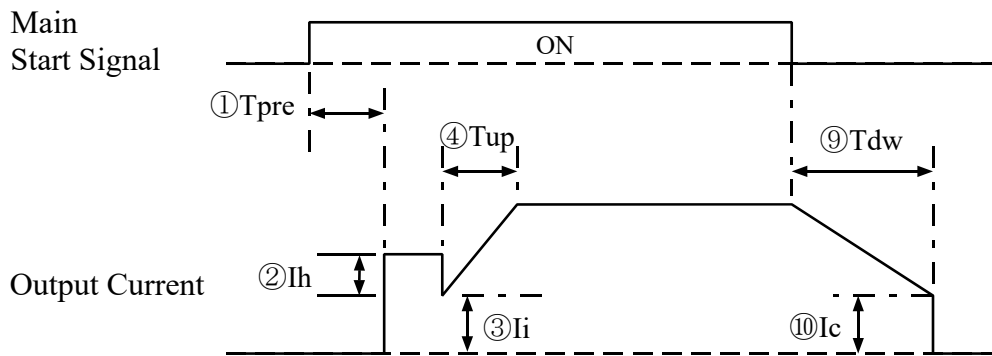

### 2T SLOPE FUNCTION OFF

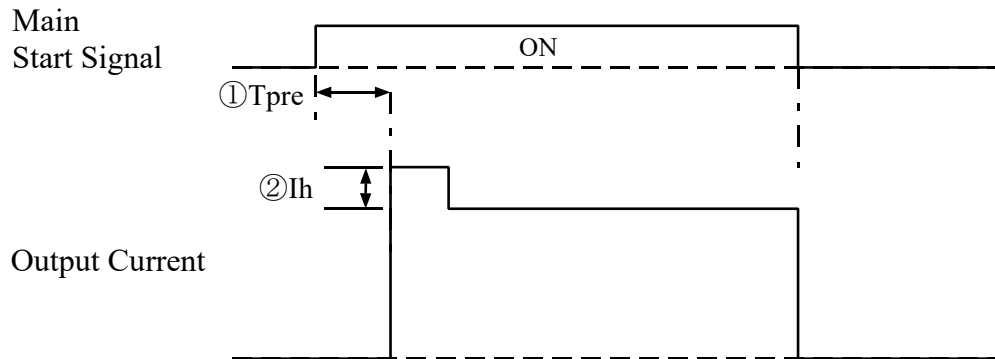

### 6.1.3. 4T/4TS/REPEAT/SEQ

In, when 4T mode is selected and the main start signal is turned OFF during the down slope, this function selects whether or not to end welding after sloping down to CRATER CUR.

In, select to have REPEAT mode enabled or disabled when you select 4T mode.

4T mode: End welding at the same time as the main start signal turns OFF.

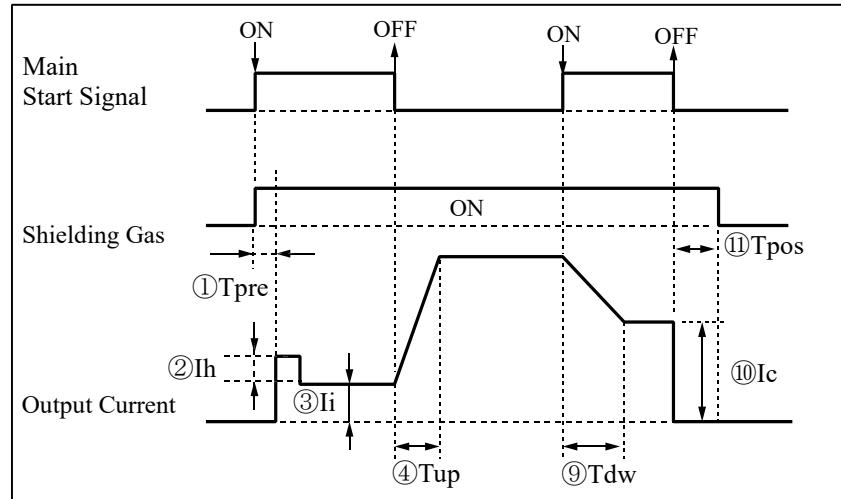

4TS mode: End welding after sloping down to CRATER CUR.

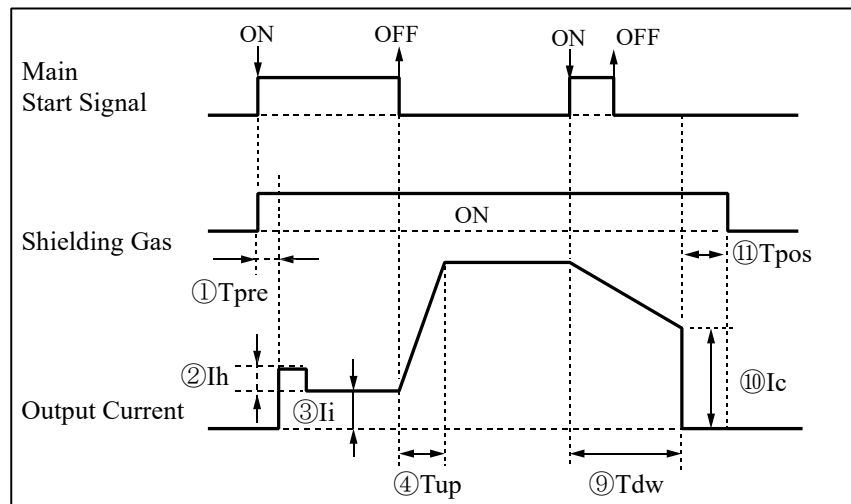

REPEAT mode: see section "4.3.2.3. REPEAT MODE".

#### **6.1.4. PULSE SIGNAL OUTPUT**

Select logic for the pulse synchronization signal (terminal number:21,22).

ON : Open Collector Signal turns ON when base current flows.

OFF : Open Collector Signal turns ON when peak current flows.

#### **6.1.5. OK TO MOVE CURRENT DETECT OUTPUT**

Select logic for the OK to move current detect signal (terminal number: 15,16).

ON : Contact "OPEN" when main current flows.

OFF : Contact "CLOSE" when main current flows.

#### **6.1.6. PILOT-CUR DETECT SIGNAL OUTPUT**

Select logic for the pilot current detect signal (terminal number 17,18).

ON : Contact "OPEN" when pilot current flows.

OFF : Contact "CLOSE" when pilot current flows.

#### **6.1.7. PILOT GAS PRE-FLOW**

Set Pilot Ignition Gas Flow amount.

## 6.1.8. ERROR SIGNAL OUTPUT LOGIC

Select logic inversion or not for the error signal (terminal number:19, 20).

ON : Contact “OPEN” when an abnormality occurs.

OFF : Contact “CLOSE” when an abnormality occurs.

## 7. DAILY INSPECTION

To optimally maintain the performance of the welding power supply and to work safely and efficiently, regularly inspect and maintain the welding power supply.

NOTE DAILY	3- TO 6-MONTH INSPECTION
Operation of the switches	Torch, work lead damage
Cooling fan rotation (Qty. 2)	
Unusual vibrations, buzzing, or odor	
Gas leaks	
Cable connections	

The welding power supply uses multiple semiconductor components such as IGBTs and diodes. Carelessly measuring the insulation resistance and dielectric strength may lead to injury to the operator or others or to welding power supply breakdown. If these tests are necessary, contact the retailer from which you purchased the welding power supply in order to request these tests from a service center specified by Sansha Electric Mfg. Co., Ltd.

 <b>WARNING</b>
<p>☆ Be extremely careful not to electrocute yourself when testing insulation resistance and withstand voltage.</p>

- Cleaning the interior of the welding power supply:  
Once or twice every 6 months, remove the top panel and side panels and remove any dust in the interior using compressed air
- Warning against electric shock:  
If you discover any conductors exposed on the input terminals or the cables, immediately replace them with new cables.
- Maintenance and inspection precautions:  
If the top panel or side panels are removed for maintenance or inspection, always ensure that the top panel and side panels are attached in their original location before operating the welding power supply once again. Please be aware that the internal cooling efficiency is reduced and may cause damage to the transformers and semiconductors if the welding power supply is operated with the panels removed.
- Inspecting the tungsten electrode:  
If the tip of the tungsten electrode becomes round or dirty, use a new electrode otherwise HF will travel with more difficulty and the electrode will lose the ability to concentrate the arc. (\*1)  
A finer welding effect will be achieved by regularly taking care of the electrode.

(\*1) The electrodes used in plasma welding are manufactured to exacting tolerances. Do not regrind or polish the electrode, replace it with a new electrode. If the point of the electrode is not centered it will cause premature failure of the tip. Refer to Torch manual.

## 8. Warning

### 8.1. Abnormality

In case of abnormality, stop the output.

Indication	Occurrence Condition	Return conditions
OVER TEMPERATURE	Abnormal temperature in the main Primary/ Secondary circuit.	Reduce the temperature of the semiconductor device to the rated value. Press the SET button.
MAIN PRIMARY OVERCURRENT	Over current flows in the main primary circuit.	Turn the power off and then on again.
PILOT PRIMARY OVERCURRENT or PILOT OVER TEMPERATURE	Over current flows in the pilot primary circuit. Or Temperature abnormality of pilot primary circuit.	Turn off the start signal. Press the SET button.
START SIGNAL ERROR	The start signal is ON when the power supply was turned ON.	Turn off the start signal. Press the SET button.
EMERGENCY STOP	The emergency stop signal was input to the automated machine terminal block.	Turn OFF the emergency stop signal and press the SET button.
PILOT IGNITION FAILURE	Pilot Arc was not established within 3 seconds of Pilot Output ON signal, or unexpected Pilot Arc outage detected.	Turn off the start signal and press the SET button.
MAIN IGNITION FAILURE	Main Arc was not established within 3 seconds of Main Output ON signal, or unexpected Main Arc outage detected.	Turn off the start signal and press the SET button.
DECREASE OF TORCH COOLANT FLOW AMOUNT	Flow rate is less than 0.4 gal/min (1.5L/min)	The flow rate is higher than 0.4 gal/min (1.5L/min). Press the SET button.
COOLANT TEMPERATURE IS TOO HIGH	Coolant temperature exceeded 158° F (70 ° C)	Reduce the coolant temperature to the rated value. Press the SET button.
PILOT GAS PRESSURE DROP	Shield gas air pressure is less than 0.24MPa (2.5kg / cm <sup>2</sup> )	Raise gas pressure more than rated value, and press the SET button.
SHIED GAS PRESSURE DROP	Shield gas air pressure is less than 0.24MPa (2.5kg / cm <sup>2</sup> )	Raise gas pressure more than rated value, and press the SET button.
COOLANT CONDUCTIVITY WARNING	Conductivity greater than 50uS/cm	Keep the coolant conductivity below 50 uS/cm.

## 8.2. ACTIONS FOR ABNORMAL OPERATION

SYMPTOM	CAUSE	ACTION
The fan is not rotating Panel LEDs are OFF	<ul style="list-style-type: none"> <li>● Distribution panel switch fuse is faulty.</li> <li>● Bad input cable connection</li> </ul>	Inspect the cable connections and securely tighten them.
The fan is not rotating Panel LEDs are ON	<ul style="list-style-type: none"> <li>● Control circuit is faulty.</li> <li>● Fan is faulty</li> </ul>	Contact our business office.
Error code displayed on the Parameter Display		See section "8.1. ERROR CODE LIST"
No gas flow when torch switch is pressed	<ul style="list-style-type: none"> <li>● Torch switch is faulty or torch switch cable is broken</li> <li>● Gas hose damage or loose connection</li> </ul>	Inspect with a tester and replace the switch or repair the cable. Repair the gas hose.
The arc does not initiate	<ul style="list-style-type: none"> <li>● Bad torch cable or base metal cable connection</li> <li>● Tungsten electrode is faulty</li> </ul>	Securely tighten the cables and repair when broken. Check for sharp pint and clean appearance of electrode. (*1)
HF does not stop even after the arc appears	<ul style="list-style-type: none"> <li>● Control circuit is faulty</li> </ul>	Contact our business office
Cannot adjust the output current	<ul style="list-style-type: none"> <li>● Control circuit is faulty</li> </ul>	Contact our business office
Severe tungsten electrode consumption	<ul style="list-style-type: none"> <li>● See Torch manual</li> </ul>	
The arc is unstable	<ul style="list-style-type: none"> <li>● Check Plasma Gas</li> <li>● Check Torch</li> </ul>	Check gas supply. (*1) See Torch Manual

(\*1) The electrodes used in plasma welding are manufactured to exacting tolerances. Do not regrind or polish the electrode, replace it with a new electrode. If the point of the electrode is not centered it will cause premature failure of the tip. Refer to Torch Manual.

## 9. OUTLINE DRAWING

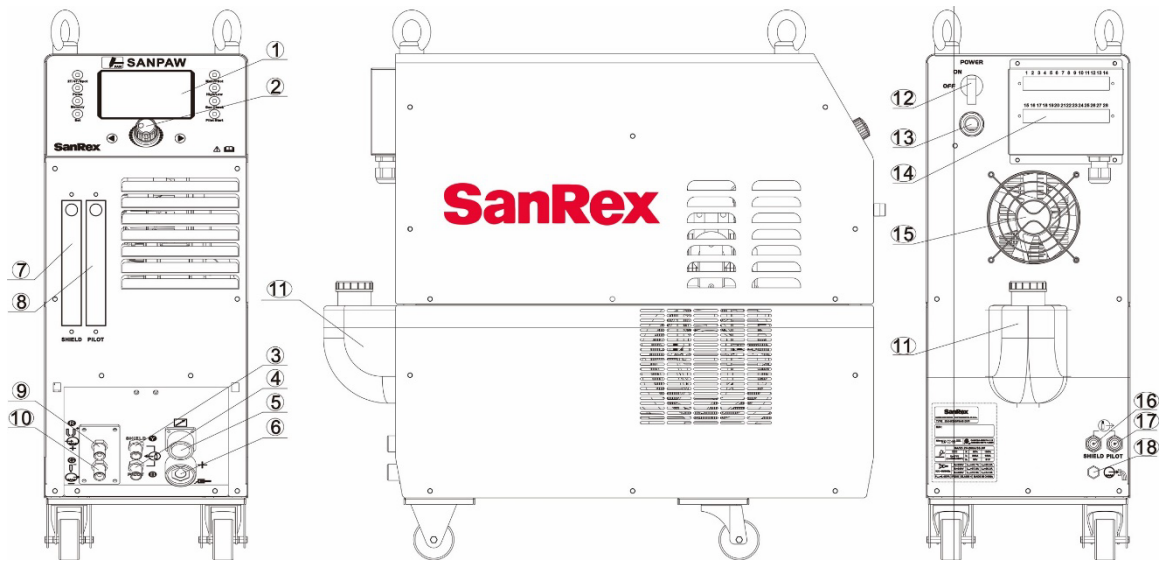

1. LCD Screen
2. Encoder
3. Shield Gas, Torch
4. Plasma Gas, Torch
5. 14 Pin Receptacle
6. 50mm Dinse Receptacle
7. Shield Gas Flowmeter
8. Plasma Gas Flowmeter
9. Positive Torch Receptacle

10. Negative Torch Receptacle
11. Coolant Reservoir
12. Power On/Off Switch
13. Primary Cable Input Clamp
14. I/O Terminal Strips
15. Cooling Fan
16. Shield Gas Input Receptacle
17. Plasma Gas Input Receptacle
18. Coolant Drain Plug

# 10. CONNECTION DIAGRAM

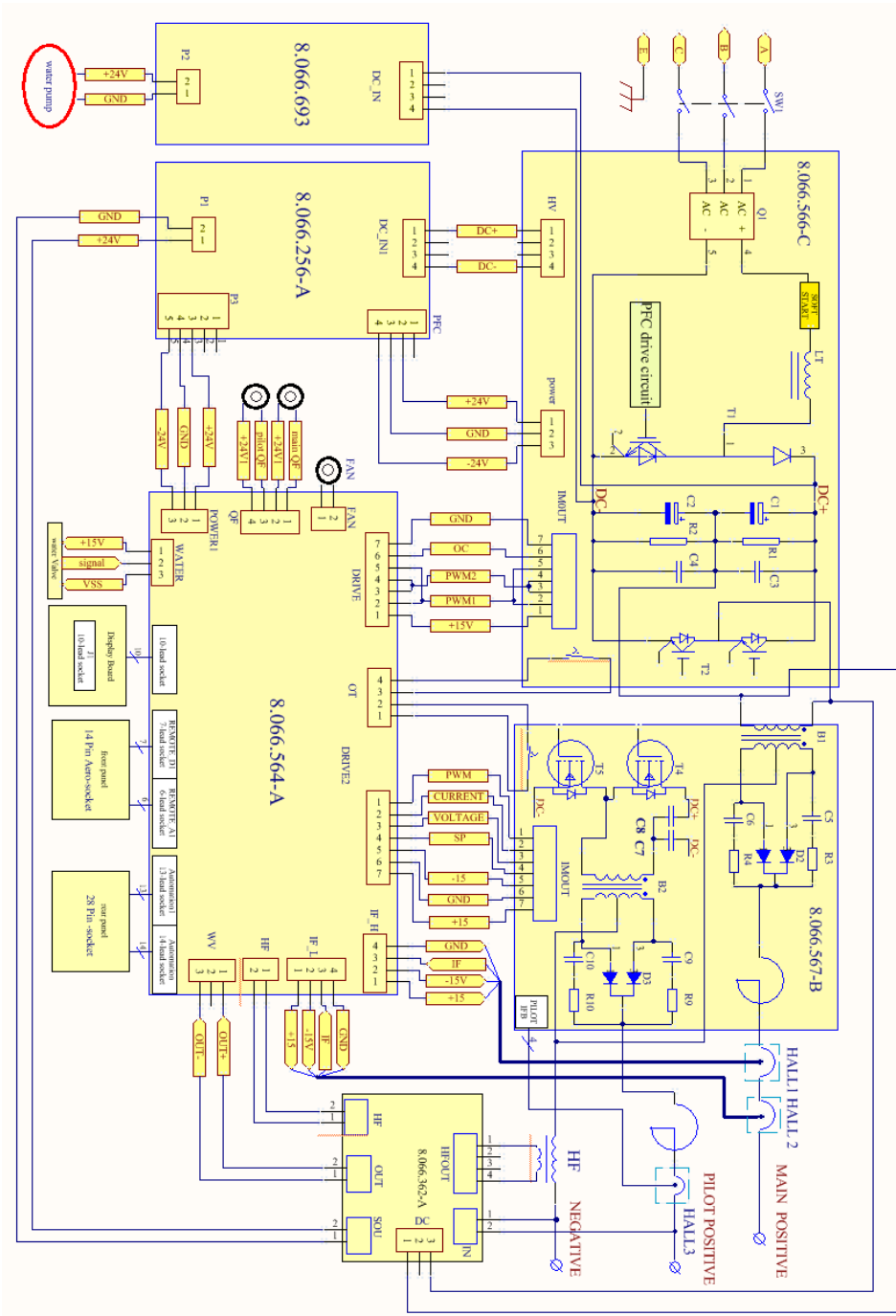

PAGE LEFT INTENTIONALLY BLANK

# 11. APPENDIX A

## 11.1. AUTOMATION I/O RELATIONSHIP SUMMARY

150PW				END USER	INVERSION Y/N
	14-PIN		TB3		
	A	MAIN START SIGNAL	1		N
	B		2		
	K	PILOT START SIGNAL	3		N
	L		4		
		GAS CHECK SIGNAL	5		N
			6		
		E-STOP SIGNAL	7		N
			8		
		USER SAVED FILE SELECTION SIGNAL	9		N
			10		
			11		
			12		
			13		
			TB4		
	M	OK TO MOVE SIGNAL	15		Y
	N		16		
		PILOT CURRENT DETECT SIGNAL	17		Y
			18		
		ERROR DETECT SIGNAL	19		Y
			20		
		PULSE SYNC SIGNAL (OPEN COLLECTOR)	21	30VDC MAX 50mA MAX	Y
			22		
+10VDC (2mA) ►	C	PEAK CURRENT OUTPUT ADJUSTMENT SIGNAL	23		N
CONTROL SIGNAL ◀	E		24		
SIGNAL RETURN	D		25		
1/10V OUT ►	H	V OUT SIGNAL	26	5mA MAX LOAD	N
1/100A OUT ►	F	A OUT SIGNAL	27	5mA MAX LOAD	N
SIGNAL RETURN	I	V/A OUT COMMON	28		N
GROUND	G				

# 12. Parts List & Exploded View

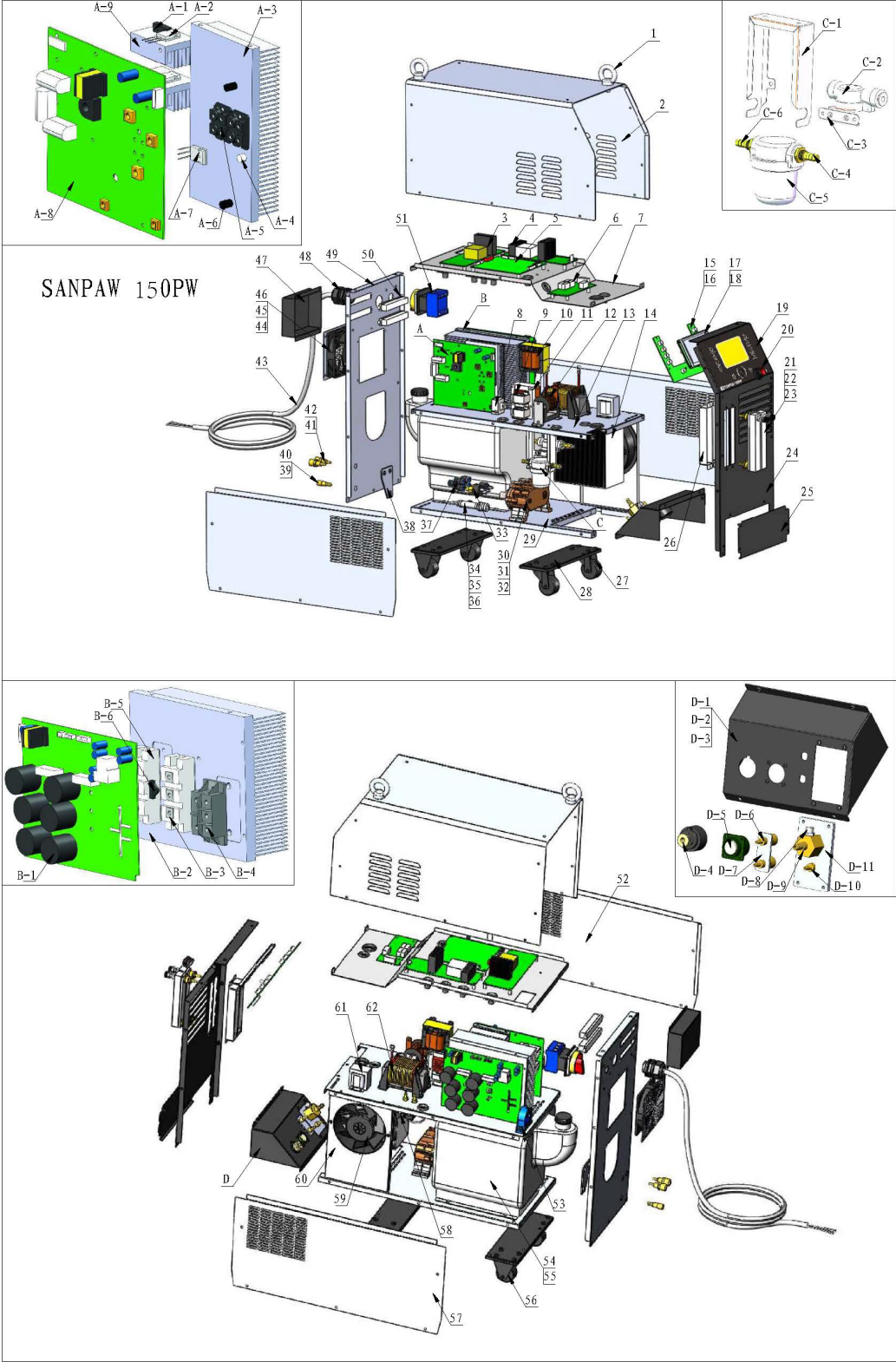

## Parts List

No.	SanRex P/N	Description	Qty.
1	7921002	Screw	2
2	E8301148	Cover	1
	N8104300	Warning label (Not Shown)	1
3	P8066256A	Switch power PCB	1
4	P8066693B	100W Water cooler Switch power PCB	1
5	P8066564C	Control PCB	1
6	P8066362	Electronic high frequency board	1
7	E8062148	Mounting plate	1
8	7321104	Hall	1
9	6272800	Hall component	1
10	F6185150	Transformer	1
11	F6271047	Inductance	1
12	6174007	High frequency	1
13	E8124150	Middle plate	1
14	6081605A	Radiator	1
15	P8066568A	Front PCB	1
16	8712304	Encoder insulating washer	1
17	7122501	LCD Screen	1
18	8303365	LCD Screen cover	1
19	N81038623	front label	1
20	7458043	Knob	1
21	7311241	Regulator	1
22	7311242	Regulator	1
23	8462196	Regulator connector	4
24	E8069138	Front Panel	1
25	E8123691	Output cover plate	1
26	8123689	Regulator support	2
27	7682010	Universal wheels	2
28	E8123081	Fixed plate	2
29	E8055148	Base plate	1
30	7710113	Water pump	1
31	8462183	Adapter	1
32	8462198	Water pipe adapter	1
33	S7232639	Pressure Switch	2

No.	SanRex P/N	Description	Qty.
34	7624152	45 degree oblique inner wire tee	1
35	8462232	Pump connector 1	2
36	8462233	Pump connector 2	1
37	7624281	Y-shaped three-way connector	2
38	E8123407	Mounting plate 2	1
39	8462234	Drain connector	1
40	8462197	Drain connector 2	1
41	8462010E	Gas connector	2
42	8940003	Copper nut	7
43	7555530	power cable 3.4M (American standard)	1
44	CF7720008A	Fan	1
45	7723207	Fan cover	1
46	E8122363	Fan mounting plate	1
47	E8123693	Protection cover	1
48	7155665	cable clamp	1
49	E8068138	Rear Panel	1
50	7207007	Line bank	2
51	S7232407	Rotary switch	1
52	E8050148	Side plate(left)	1
53	7321017	Hall	1
54	8831100	Plastic tank	1
55	E8123389	Water tank bracket	1
56	7682016	Fixed wheel	2
57	E8051148	Side plate(right)	1
58	7253013	Solenoid valve	2
59	CF7720012	Fan	1
60	E8122001	Fan Mounting plate	1
61	F6271639B	Inductance	1
62	F6190105	PFC	1
63	N88603171	Nameplate (Not Shown)	1
<b>A</b>			
A-1	TH7231275	Thermostat	1
A-2	7425450	IGBT	2
A-3	8425612	Heat Sink 1	1
A-4	TH7445401	NTC thermal resistance	1
A-5	D7421808A	fast recovery diode	2

<b>No.</b>	<b>SanRex P/N</b>	<b>Description</b>	<b>Qty.</b>
A-6	8128711	Connecting column	2
A-7	D7421086	Fast recovery diode	1
A-8	P8066567C	200PFC PCB	1
A-9	8426668	Pilot heat sink	2
<b>B</b>			
B-1	P8066566C	PFC PCB	1
B-2	8425613	Heat Sink 2	1
B-3	7425114	IGBT	1
B-4	D7411124A	3ph rectifier	1
B-5	7425115	IGBT	1
B-6	TH7231280	Thermostat	1
<b>C</b>			
C-1	E8123694	Fliter bracket	1
C-2	7251008	Water flow sensor	1
C-3	E8123385	Gas valve bracket	1
C-4	8462195	Fliter connector	1
C-5	7313017	Water filter	1
C-6	8462195A	Fliter connector	1
<b>D</b>			
D-1	E8065148	Output plate	1
D-2	N81043392	Output label (Not Shown)	1
D-3	N8104371	Output label (Not Shown)	1
D-4	7152312A	35-50mm2 Dinse plug	1
D-5	7132014	14pin areo-socket	1
D-6	8462191	Gas connector	2
D-7	E8123406	Mounting plate 1	1
D-8	TH7231277	Thermostat	1
D-9	8462192A	Water connector	1
D-10	8462192	Water connector	1
D-11	8751007	Water connector insulation plate	1
D-12	7624503	Plug (Not Shown)	4
D-13	7505370	Plug seal (Not Shown)	4

## 13. Quick Start Menu Guide

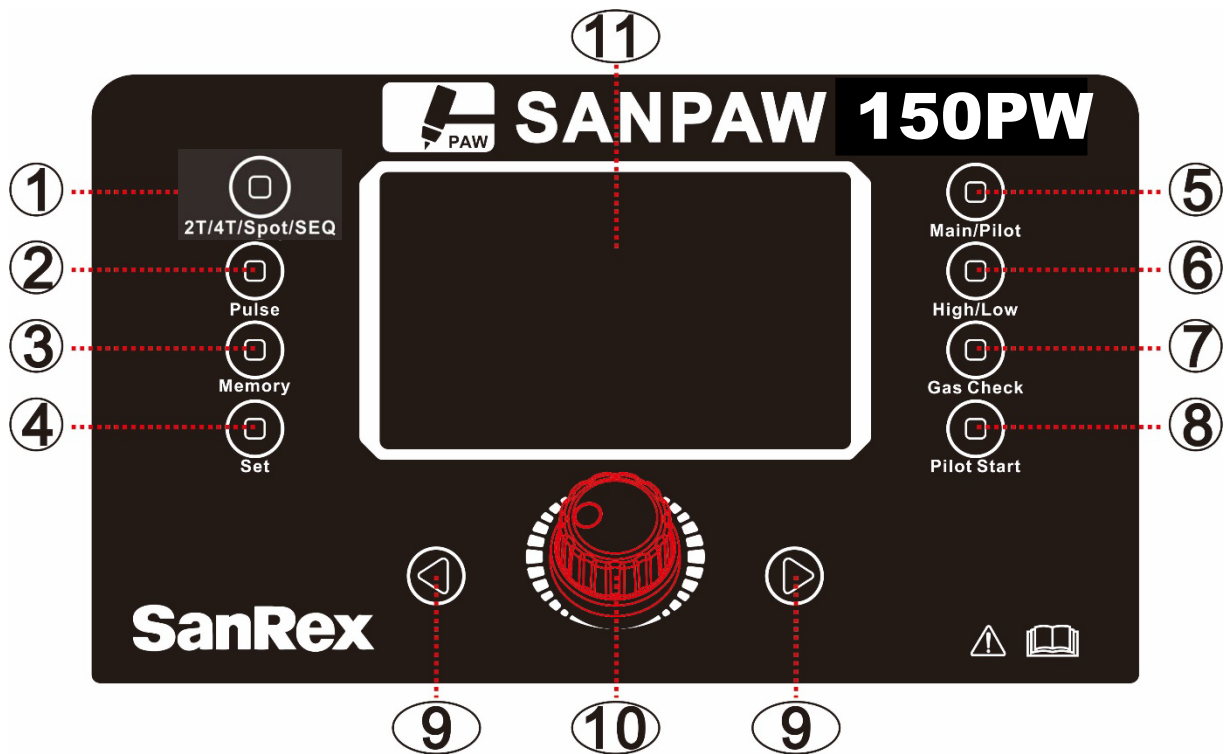

### Initial Setup

This guide assumes Input power, Remote Interface, torch, work lead, gas has been connected, coolant reservoir filled, and torch primed.

Encoder Knob (10) - Turn to change the value of the parameters. In set mode push to select parameter.  
 Left and Right Arrow buttons (9) - Pressing either of these two buttons changes the selection of welding parameters. The parameters that can be selected differ according to the welding process and waveform mode setting.

See section 4.1 for detailed description of front panel user interface controls.

1. Setting Main Functions.
  - a. 2T/4T/Spot (1). 2T function will be most common.
  - b. Pulse (2) – if required for weld procedure.
  - c. Memory (3) – To be used to save and load the state of the Configured welding process.
  - d. Set Function (4) – Press the Set Button. Below screen will be displayed.

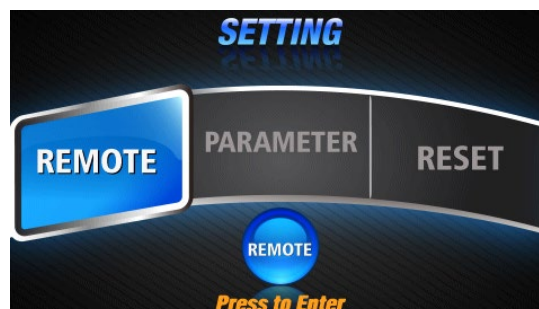

- e. Remote (Remote Amperage) setting will be highlighted. Push the Encoder Knob. Turn to change remote ON or OFF. In OFF mode Amperage is adjusted from front panel Encoder knob, in ON mode amperage is controlled remotely through the 14 pin receptacle or I/O Terminal.
  - i. Note: Output remote setting has no effect on the Output Contactor. Output Contactor is always remote. Must use remote device to turn ON remote contactor.
- f. Parameter setting covers adjustments for Peak-Cur Max Settings, 2T Slope Functions, Select 4T/4TS/Repeat, Pulse Signal Output, Ok-To-Move Current Detect Output, Pilot-Cur Detect Signal Output, Pilot Gas Pre-Flow, External Call for User Saved Data, Error Signal Output.
  - i. See Section 5.1 for detailed instruction.
  - ii. Use Arrow keys to scroll through Parameters. Use Encoder Knob to change Parameter.
- g. Press the SET button to exit.
- h. Set weld sequence functions. Use the Left and Right Arrow Buttons (9) to highlight the function. When selected the Function will glow Red. Use the Encoder Knob (10) to set Function Parameter.

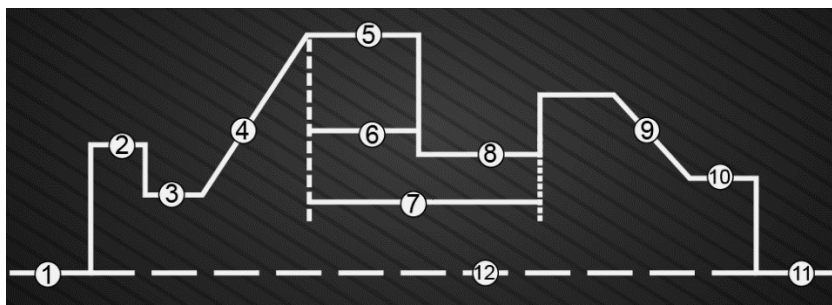

- i. Pre-Flow Function (1). The time gases will flow before Welding Arc Transfer.
- ii. Hot Start Function (2). Additional current at start of weld to establish Weld Puddle.
- iii. Initial Current (3) Used in Slope Mode.
- iv. Weld/Pilot/Pulse Current (5). Sets Weld current output. When in remote function sets Maximum current level. Sets Pilot current and Peak Current setting when in Pulse Mode.
- v. Pulse Width (6). Used in Pulse Mode.
- vi. Freq. (7) Pulse Frequency. Used in Pulse Mode.
- vii. Pulse Base Current (8). Used in Pulse Mode.
- viii. Down Slope Time (9). Used in Slope Mode.
- ix. Crater Current (10). Used in Slope Mode.
- x. Post Flow (11). Sets Post Flow time after weld stops.
- xi. Spot Timer (12).
- i. Main/Pilot (5). Sets digital meter to show Main welding current or Pilot Current.
- j. High/Low (6). Welding Range.
- k. Gas Check (7). Used to Purge and set welding gas parameters per Welding Procedures.
- l. Pilot Start (8). Used to initiate pilot arc. Do not turn on Pilot without pre-purge of Plasma Gas.
- m. Ready to Weld.

# SanRex

## SANREX CORPORATION (USA)

50 Seaview Boulevard Port Washington, NY 11050-4618, U.S.A.

TEL : +1-516-625-1313 FAX : +1-516-625-8845

URL : <http://www.sanrex.com>

## SANSHA ELECTRIC MFG. CO., LTD. (Japan)

3-1-56, Nishiawaji, Higashiyodogawa-ku Osaka Japan 533-0031

TEL +81-6-6321-0321 (Representative) FAX +81-6-6321-8621

TEL +81-6-6325-0500 (Sales and marketing) FAX +81-6-6321-0355

URL : <http://www.sansha.co.jp>